



*Procured and manufactured with Belco Forest Products' unrivaled standard of excellence, Armor Coat® Trim & Fascia is a premium, factory primed, whitewood product that provides customers with an aesthetically pleasing, safe-for-the-environment alternative to other products available.*

**ARMOR COAT™**  
TRIM & FASCIA

**Installation & Handling Instructions**

**Storage:**

Armor Coat® products must be stored flat, in a clean and dry environment until the time of installation; avoid any contact with the ground, concrete, or standing water.

**Caulking:**

Armor Coat® products must have all butt and scarf joints caulked with a quality, exterior rated, flexible caulk prior to paint application. All non-trim/fascia abutments must be caulked and sealed with the same exterior grade caulk. Speak with your Armor Coat® representative for a list of suitable caulking products.

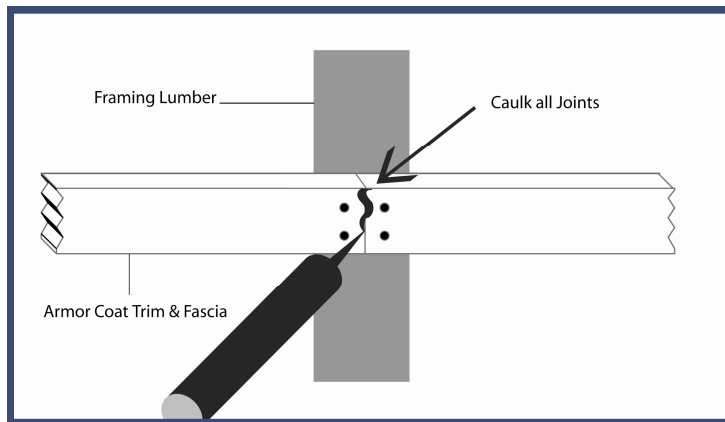

**Priming Cut Ends:**

All ends exposed due to post-manufacturing field cuts must be sealed with a premium, 100% acrylic primer, to ensure that no fiber is left exposed to the elements.

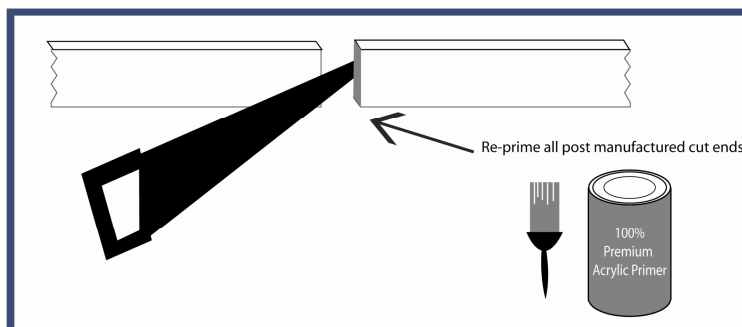

Continued...

### Fastening:

Double nail all joints (minimum nail size - 7 penny). Do not nail any less than 1/2" from any edge. Drive nails perpendicular to the framing lumber and the Armor Coat® product; drive all nails flush with the Armor Coat® product's surface.

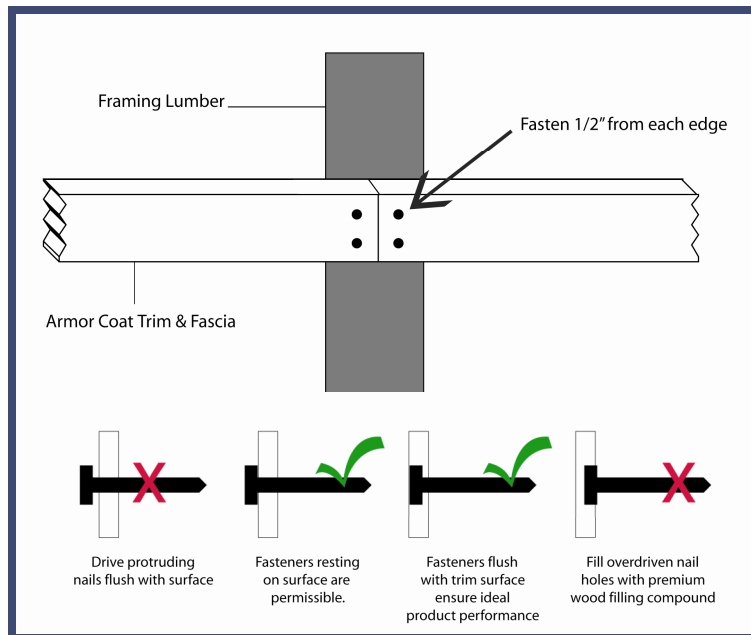

### Top Coat Preparation:

Armor Coat® products must be clean and free from dirt, dust, mildew and any other foreign particulate matter prior to painting.

- Remove dirt and dust by gently washing trim surface with a brush & water
- DO NOT use a pressure washer
- Allow ample dry time for all Armor Coat® products prior to painting

### Top Coating:

Armor Coat® products must be top coated with two coats of a quality, un-thinned, 100% acrylic exterior grade paint that is intended for wood siding. This top coat must be applied to a clean Armor Coat® surface within 60 days of installation. Paint must be applied and maintained, including repainting to avoid any exposure to the elements, in strict accordance with the manufacturers' specifications. Belco Forest Products, Inc. does not warrant the primed surface from blistering and peeling resulting from breakdown of the top coat paint film.

