

# ELECTRIFIED HINGES



## Our New Connection

Our Continuous Hinge Modules are now supplied with Micro Fit 3.0 Molex connectors. This means even more added security for your hotels, hospitals, museums, banks, private businesses, schools, and everywhere else protection is important to your clients. Benefits are not just limited to your clients. Designed with you in mind, installations are simpler, quicker, and smoother. Some features:

- 22 gauge wires
- Tough and durable
- Standardized concealed plug-in connector
- Applies to our CC, SER, and ACC models



LISTED  
Door Hinges  
76Y2

- Concealed plug connectors eliminate the need for separate or exposed wiring.
- Standard connectors and polarized mating parts make installation quick, easy, and smooth by simply snapping ends together.
- Compatible with ElectroLynx™ Connections.

### HEALTH CARE



### LABORATORIES



### AIRPORTS



### UNIVERSITIES



## Technical Specifications:

### Electrical:

QC12 hinge contains an 8 position and 4 position microfit 3.0 female housing.  
Wire is 22AWG  
Each conductor is capable of carrying 7 amps at 24 volts with a 16 amp in rush current for 820 milliseconds.

### Types:

#### SER-Serviceable/Removable Module

The hinge is furnished to be installed in three sections allowing the current carrying cable to be serviced or replaced without removing the door from the frame.

#### ACC-Accessible Feature

The hinge is furnished to be installed in a single section with the leafs modified to pivot at the location of the current carrying cable to allow access to the cables and connected wiring.

#### CC- Concealed Circuit

The hinge is furnished to be installed in a single section.

## ELECTRIFIED FM HINGE

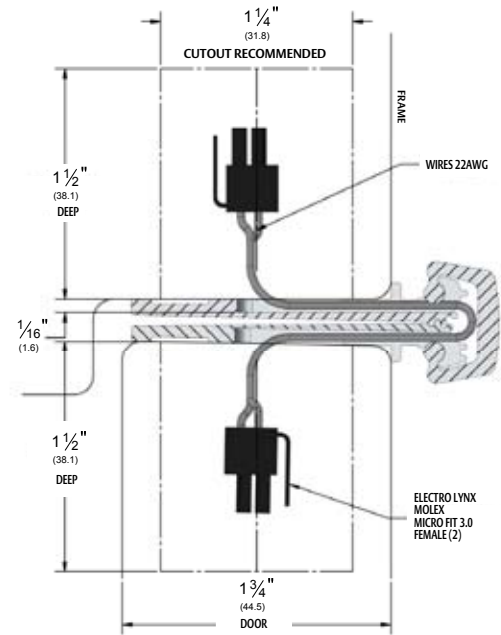

*"Using Pemko SER hinges has saved us time and money. The SER allows us to keep the electrical connections protected until the access control system is installed. Less damage, ease of installation, SER's should be standard for all through wire applications."*



## ELECTRIC HINGE SOLUTIONS (SER shown)



ASSA ABLOY

### Pemko Manufacturing Company

MEMPHIS, TN USA  
PO Box 18966  
Memphis, TN 38181  
PH: 800 824-3018  
FAX: 800 243-3656

VENTURA, CA USA  
PO Box 3780  
Ventura, CA 93006  
PH: 800 283-9988  
FAX: 800 283-4050



VANCOUVER, BC CANADA  
103-2480 Mt. Lehman Rd.  
Abbotsford, BC V2T 6W3  
PH: 877 535-7888  
FAX: 877 535-7444

TORONTO, ON CANADA  
160 Four Valley Dr.  
Vaughan, ON L4K 4T9  
PH: 877-535-7888  
FAX: 866-243-9817