

Vibro-Curb III General Assembly and Installation Instructions

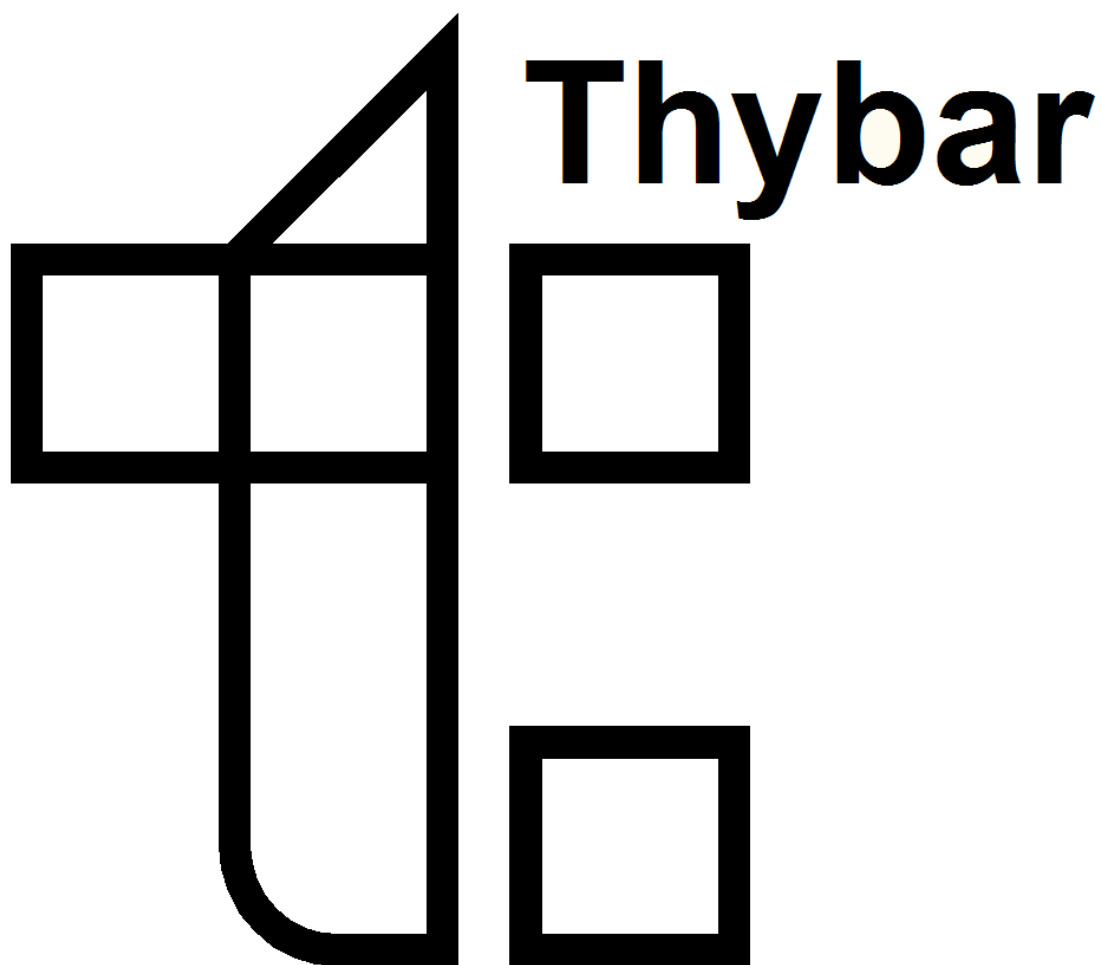

Main Plant & Office
913 South Kay
Addison, Illinois 60101
630/543-5300
FAX 630/543-5309
1-800-666-CURB(2872)

Dallas Plant & Office
13801 Senlac
Farmers Branch, Texas 75234
972/416-6220
FAX 972/418-6713
1-800-777-CURB(2872)

Louisville Plant & Office
10200 Bunsen Way
Louisville, Kentucky 40299
502/499-5480
FAX 502/499-5481
1-800-993-CURB(2872)

Akron Plant & Office
44 East South Street
Akron, Ohio 44311
330/762-0061
FAX 330/762-0914
1-800-837-CURB(2872)

Reno Plant & Office
711 Denmark Drive
McCarran, NV 89434
775/343-0600
FAX 775/343-0606
1-866-917-CURB(2872)

General instructions

refer to the unit manufacturer curb cut and as built drawing

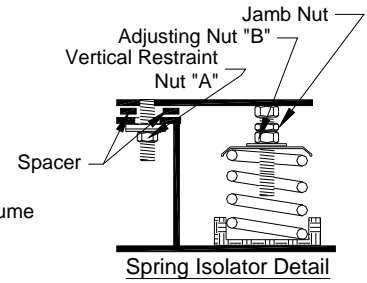
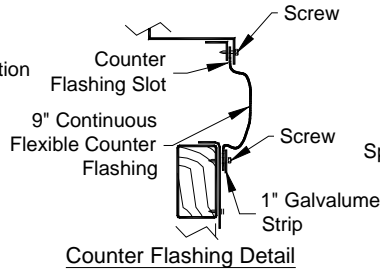
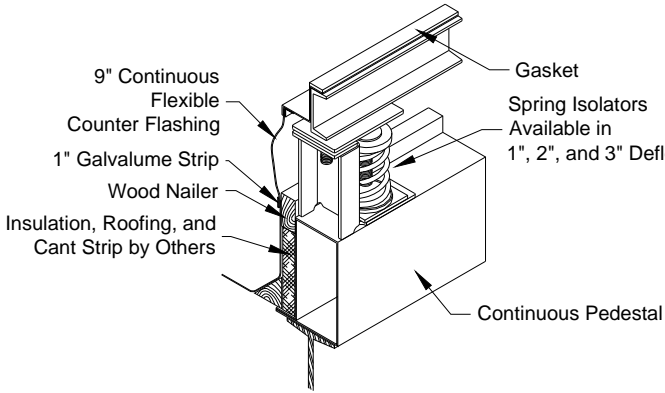

Typical Vibro-Curb III Detail

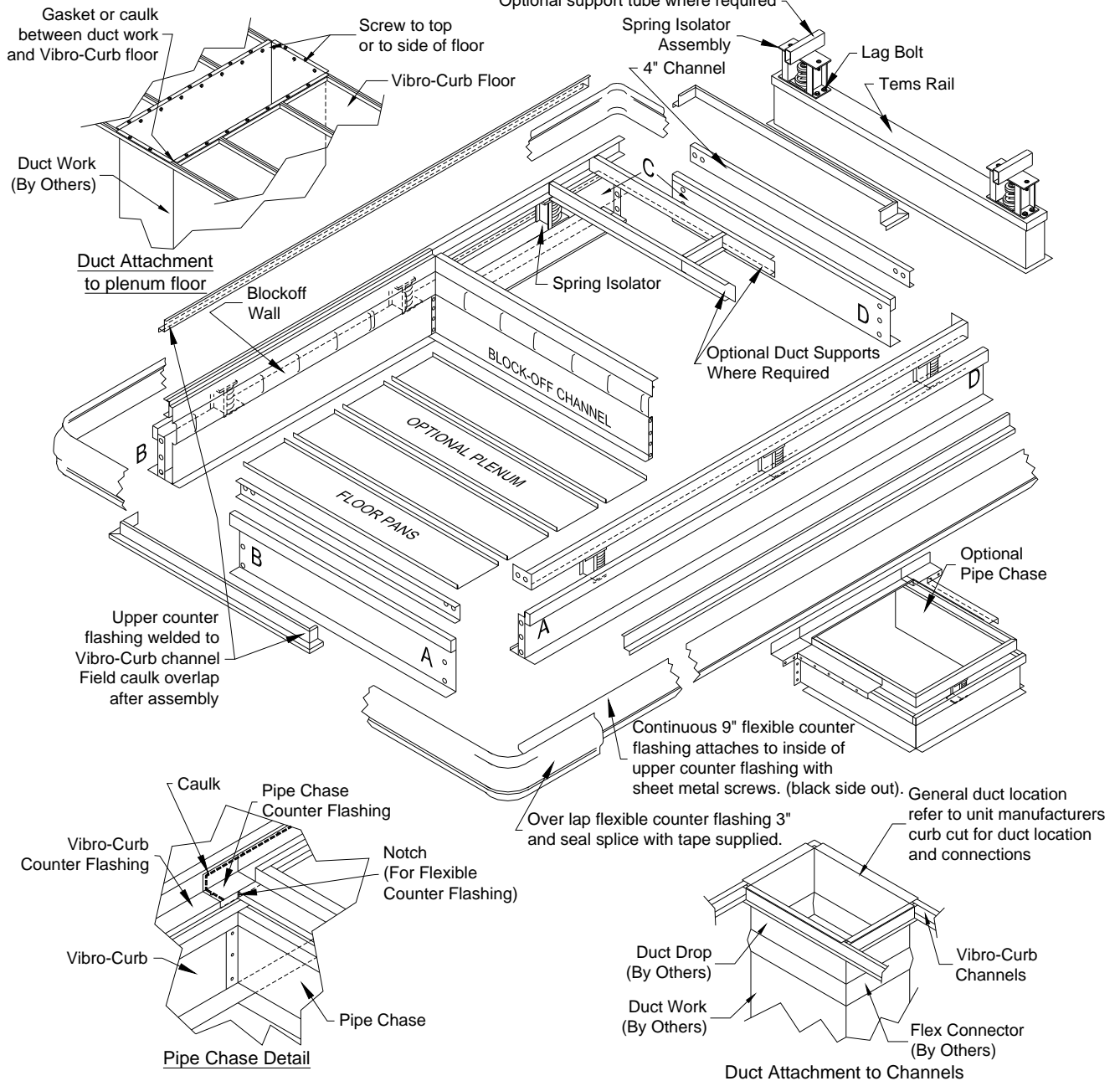

Rigging:

Eyebolts should be screwed down and tight. Carefully hoist all pieces on to roof. See ThyCurb support recommendation sheet before installing (Bottom of Page 4).

Assembly:

Note: Vibro-Curb III can be assembled at ground level and then rigged onto roof or pieces can be hoisted onto roof deck for assembly.

1. Assemble all pieces as shown using bolts provided in separate box.
2. Make sure all pieces are for designated unit number or letter.
3. Pieces should be joined by matching letters. (A to A, B to B etc..)
4. Install all cross channels after perimeter of curb is assembled. Leave all bolts loose.
5. Check the curb assembly for squareness by measuring the curb diagonally in both directions. Both measurements should be equal.
6. Tighten all bolts and fasten Vibro-Curb III to roof support members of roof deck. Fasten with mechanical fasteners or weld 12" o.c. (or as recommended by structural engineer or architects details & specifications.)

Optional TEMS Rail:

1. Locate TEMS Rail as per curb drawing supplied with shipment.
2. Fasten spring isolator assemblies to TEMS Rail with lag bolts or by welding (Reference factory drawing for location).

Optional Pipe Chase:

1. Locate pipe chase as per curb drawing supplied with shipment.
2. Apply a generous amount of caulk sealant under counter flashing of pipe chase and along the back edge.
3. Place pipe chase against Vibro-Curb III and attach to curb wall by installing sheet metal screws through vertical flanges in pipe chase.
4. Press down on counter flashing and fasten to channel on Vibro-Curb III either with screws or rivets. Make sure sealant oozes out of edge and then finger tool smooth.
5. Cut notches on counter flashing of Vibro-Curb III just behind the counter flashing of the pipe chase. (As shown in pipe chase detail)

Optional Plenum Assembly:

1. Screw block-off channel to sidewall of curb using provided Tek screws. Wrap flexible connectors at corners and staple.
2. Screw floor panels in place at bottom of return air plenum. Floor panels must be supported. Field crimp and caulk all seams air tight. Locate and field cut openings for return air duct.

Optional Condenser Drain Pan Assembly (See condenser drain pan detail on page 4):

Note: Do not penetrate drain pan

1. Place support channels on tabs to support pans.

Standing Seam Type

1. Set first pan with male lock on the condenser end of curb and the support channel.
2. Fill female side of seam with caulk and install over male seam.
3. Button punch standing seams every 8" o.c.
4. Repeat these steps as necessary for additional pans.

Shingle Type

1. Remove protective backing from 2 ½" mastic tape at condenser end.
 2. Begin with panel #1 and lay panels in place ending with panel #3. Do not secure until all panels are in place and in the right locations.
 3. Secure all panels around perimeter and across midsections with self-drilling rubber washer screws 3" o.c. (Traxx 2).
 4. Caulk all corners and seams with urethane caulk.
7. Remove eyebolts and apply adhesive backed gasketing provided with curb to the entire perimeter of the top of roof curb and all supply & return channels.
 8. Ductwork can now be installed if duct supports were supplied. Ductwork must have flex connection to allow proper isolation. **Note: insure that duct does not come in contact with roof if canvas connector is installed below roofline. Refer to the unit manufacturer curb cut for duct locations and connections.**
 9. Rooftop unit can now be set.

Activating spring isolators (see spring isolator detail)

Note: units must be set in place before activating spring isolators.

1. Loosen vertical restraint nut "A" to bottom of bolt (**Do Not Remove**)
2. Loosen jamb nut.
3. Turn spring adjustment nut "B" (clockwise) until 1/4" spacer can be easily removed.
4. Continue around Vibro-Curb III activating springs as described above.
5. After all spacers are removed use adjustment nut "B" to level unit for operation
6. Adjust the leveling bolts starting at the lightest corner.

***Do not attempt to isolate (or float) the unit by tightening the first spring all the way down.**

Progress through the process by making only a few turns of the adjustment nut "B" at each isolator location. Repeat as required until unit is at proper operating height. Lock jamb against nut "B" to prevent movement.

Counter flashing:

The counter flashing can be installed after the unit is set and the roofer has attached roofing felts.

1. Insert top of flexible counter flashing into counter flashing slot as shown on detail. Secure counter flashing by screwing the provided Tek screws through pilot holes making sure that rubber is inside slot. Do not over tighten and strip sheet metal slot. Overlap rubber flashing 3".
2. Clean mating surfaces of 3" overlap with mild soap solution. Dry mating surfaces thoroughly and apply supplied seam sealer tape between seam overlap. Press seam together to insure a weather tight seal.
3. Fasten bottom of rubber flashing to wood nailer as shown with supplied Tek screws and 1" Galvalume strip. Do not over tighten screws and strip wood nailer. Do not pull rubber flashing tight when screwing to wood nailer.

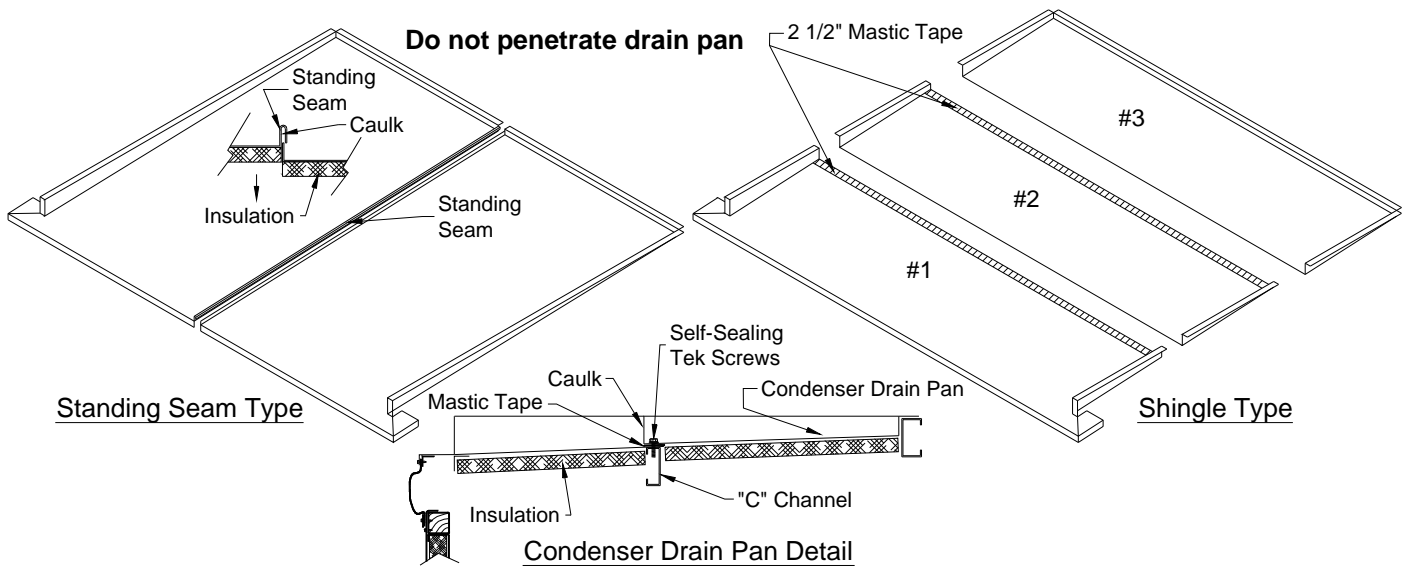

ThyCurb Support Recommendations for Vibro-Curb III

Vibro-Curb III pedestal must be fully supported. Improper supporting of Vibro-Curb III pedestal will cause pedestal to lean or tip.

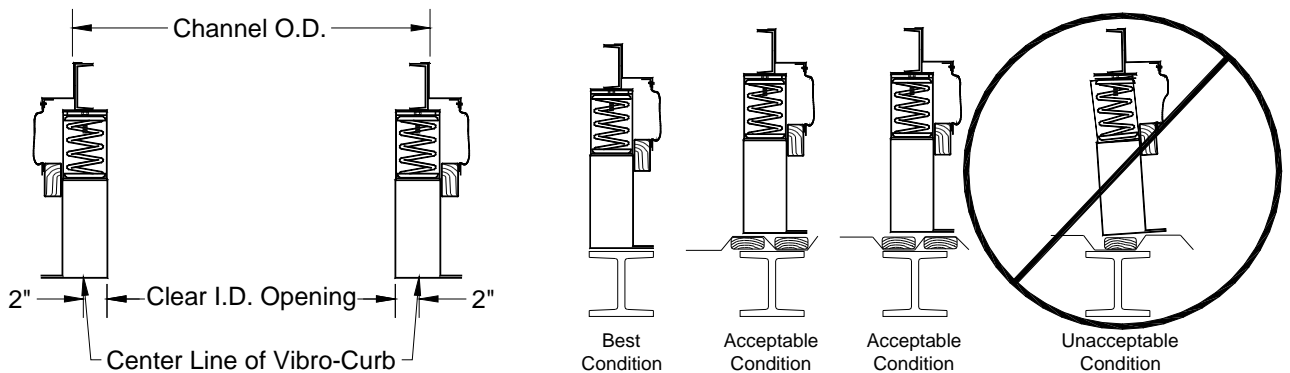

Note: These instructions are meant as a general guide only. Some variations may occur, refer to as built drawings before proceeding.