

TEMPERED GLASS BALUSTRADE

MATERIAL:

STAINLESS STEEL
BRASS/BRONZE
ALUMINUM (extruded)

FINISHES:

See Page 02

ADDITIONAL FEATURES:

BASE can be SURFACE MOUNTED, BUILT UP with WOOD and CLAD to MATCH CAP.

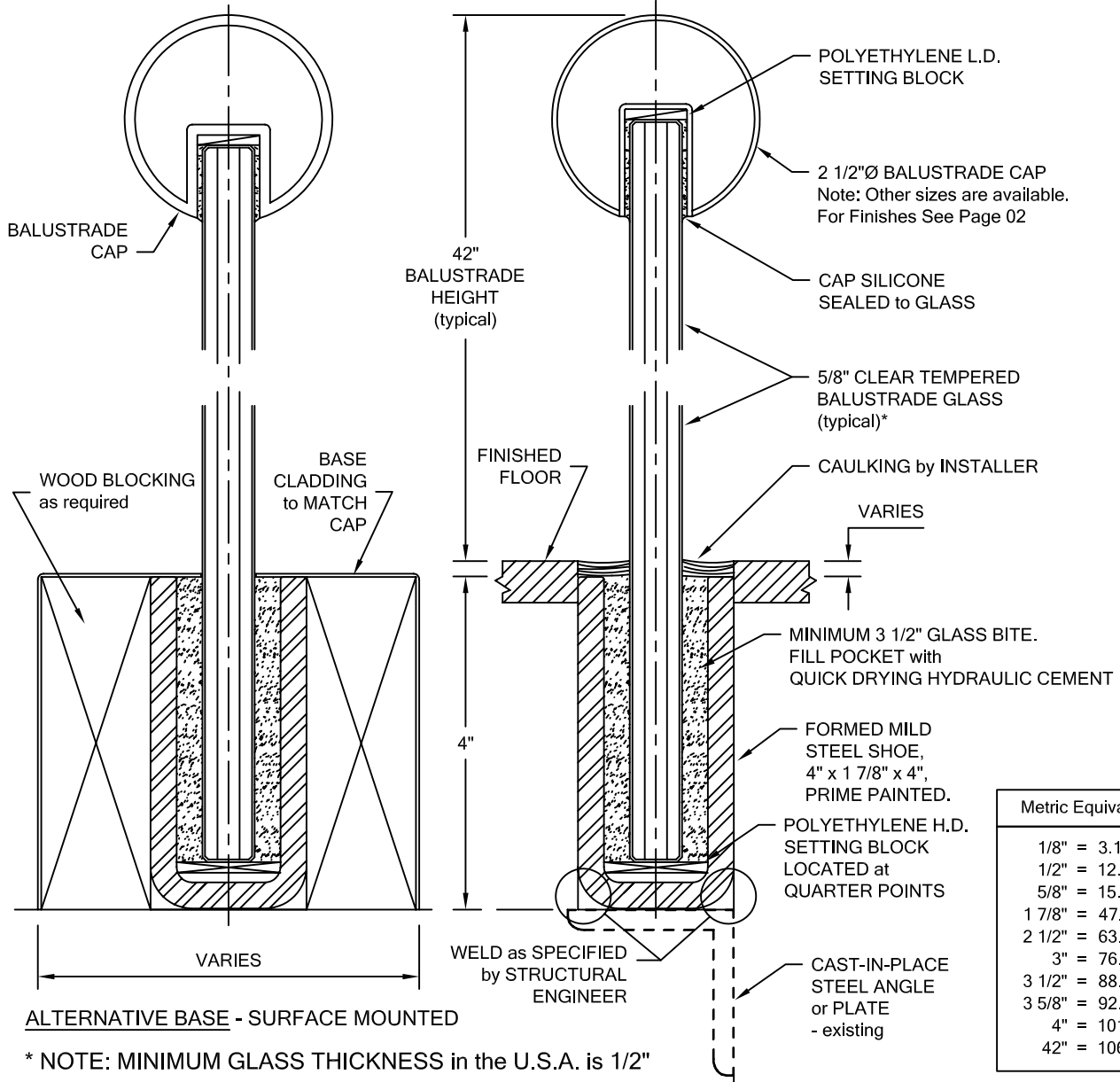
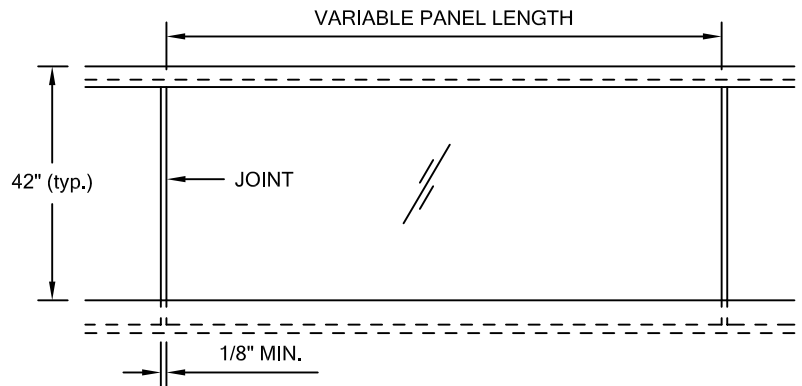

Metric Equivalents	
1/8"	= 3.17 mm
1/2"	= 12.7 mm
5/8"	= 15.9 mm
1 7/8"	= 47.6 mm
2 1/2"	= 63.5 mm
3"	= 76.2 mm
3 1/2"	= 88.9 mm
3 5/8"	= 92.1 mm
4"	= 101.6 mm
42"	= 1067 mm

ALTERNATIVE BASE - SURFACE MOUNTED

* NOTE: MINIMUM GLASS THICKNESS in the U.S.A. is 1/2"