

Application and Design

ESD-603D is an extruded aluminum louver with high performance drainable blades designed specifically for applications having extremely high structural design loadings. The design characteristics of model ESD-603D allow this product to meet the performance requirements established by the Florida Building Code and Miami-Dade County. Model ESD-603D has been tested in accordance with and passes the following Miami-Dade County test protocols: **TAS 201** (Large Missile Impact Test), **TAS 202** (Uniform Static Air Pressure Test) and **TAS 203** (Cyclic Wind Loading Test). Model ESD-603D is qualified to meet the above-mentioned Miami-Dade County test protocols based on an individual rough opening size of 60 1/2 in. W x 120 in. H with a maximum design load of 138 lbs/sq ft. The unique anchorage system designed and supplied by Greenheck allows for a swift and inexpensive installation of an individual louver section within an opening. This anchorage system, required only at the head (top) and sill (bottom), also allows for a simple installation of multiple louver panels within an opening greater than 60 1/2 in. in width without the need for additional vertical reinforcing members.

Florida Building Code Approval Number: 4826.1

Standard Construction

Frame: Heavy gauge 6063T5 extruded aluminum, 6 in. x .125 in. nominal dimensions.

Blades: Drainable design, 6063T5 extruded aluminum, .125 in. nominal wall thickness mechanically fastened and welded to jambs positioned at 37° and 45° angles on approximately 6 in. centers.

Anchorage Plates: Heavy gauge steel.

Birdscreen: 3/4 in. x .051 in. flattened expanded aluminum. Screen is mounted on inside (rear).

Finish: Louver - Mill.
Structural support and anchor plates - Perma-Tector™.

Minimum *R.O. Size: 12 in. W x 15 in. H

Maximum *R.O. Size: 60 1/2 in. W x 120 in. H

*Represents "Rough Opening"

Features

- No site welding or additional structural supports required. Louver sections may be installed side-by-side without additional framing.
- Louver is qualified for installation into concrete, masonry block, and structural steel framed openings.
- Unique anchorage system designed and supplied by Greenheck allows for a swift and inexpensive installation.

Options

- A variety of bird and insect screens
- A variety of architectural finishes including:
 - Clear anodize
 - Integral color anodize
 - Baked enamel
 - Kynar
- Sill extensions

Note: Louver size is based on rough opening. Actual louver height does not include the top and bottom anchor plates. See below for actual louver panel size.

Single Panel: Actual width = rough opening - .75
Actual height = rough opening - 2.25

Multiple Panel: Actual width = (rough opening - .75)/Number of panels
Actual height = rough opening - 2.25

Miami-Dade Notice of Acceptance Number: 00-0929.13

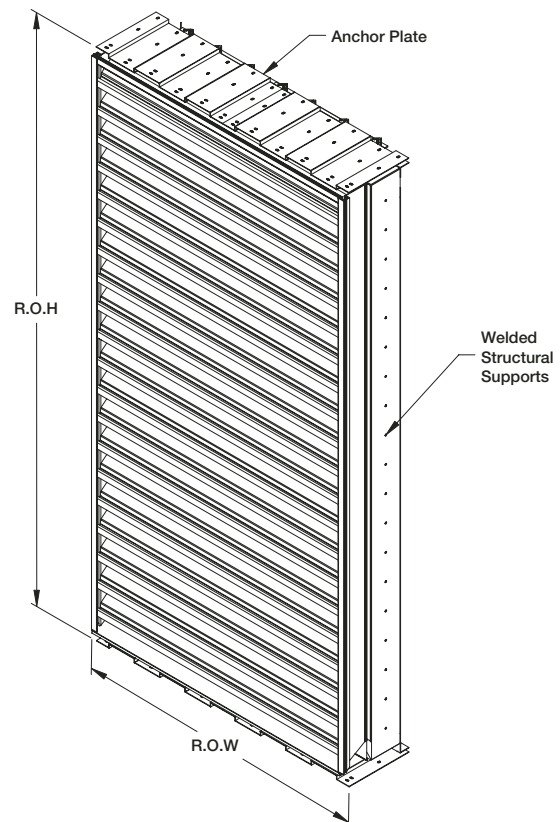

Airflow Resistance (Standard Air - .075 lb/ft³)

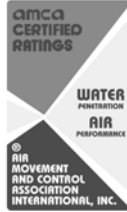
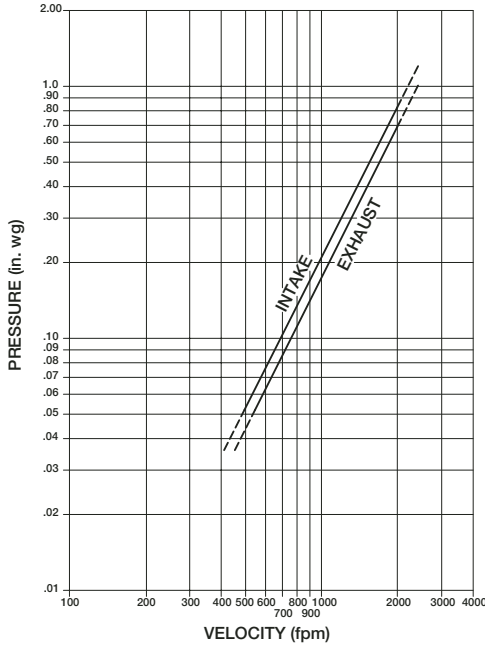

Greenheck certifies that the model ESD-603D shown herein is licensed to bear the AMCA Seal. The ratings shown are based on tests and procedures performed in accordance with AMCA Publication 511 and comply with the requirements of the AMCA Certified Ratings Program. The AMCA Certified Ratings Seal applies to air performance ratings and water penetration ratings.

Water Penetration (Standard Air - .075 lb/ft³) (Test Size 48" x 48" - 15 minute test period)

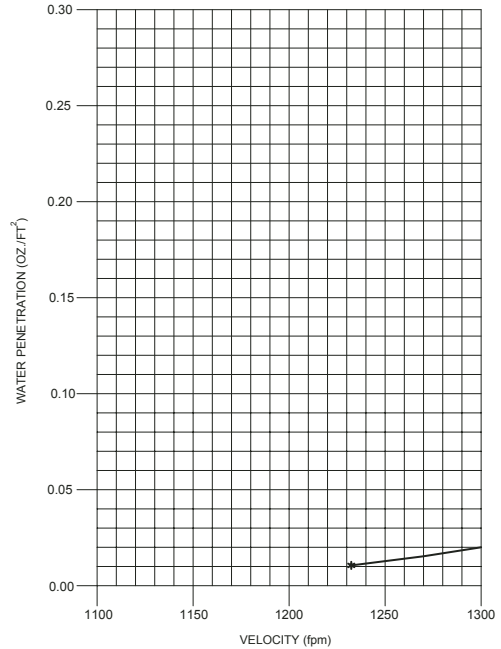

* (-BEGINNING POINT OF WATER PENETRATION IS 1232 FPM)

Model ESD-603D resistance to airflow varies depending on louver application (air intake or air exhaust). Free area velocities (shown) are higher than average velocity through the overall louver size. See louver selection information.

The Water Penetration Test provides a method for comparing various louver models and designs as to their efficiency in resisting the penetration of rainfall under specific laboratory test conditions. The beginning point of water penetration is defined as that velocity where the water penetration curve projects through .01 oz. of water (penetration) per sq. ft. of louver free area. ***The beginning point of water penetration for Model ESD-603D is 1232 fpm free area velocity.** These performance ratings do not guarantee a louver to be weatherproof or stormproof and should be used in combination with other factors including good engineering judgement in selecting louvers.

ESD-603D Specifications

Louvers meeting the following specifications shall be furnished and installed where shown on the plans and/or as described in schedules. Louvers shall be stationary type with horizontal drainable blades within a 6 in. deep louver frame. Louvers must conform to Miami-Dade County Protocols: TAS 201, TAS 202, and TAS 203 based on a maximum design load of 138 lbs/sq ft. (corresponds with a 150 mph wind along the coast at a maximum elevation of 33 ft) when mounted within a concrete, masonry block, or structural steel framed opening. Louver blade and frame materials to be 0.125 in. thick 6063T5 extruded aluminum. Louver blade to frame and louver frame to frame connections shall be both mechanically fastened with 300 series stainless steel threaded fasteners and welded. Louver blades shall be positioned at 37 and 45 degree angles on approximately 6 in. centers. Louvers shall have a maximum factory assembled section limitation for a rough opening no less than 60 1/2 in. W x 120 in. H. Louver frames shall be reinforced with rear mounted heavy gauge perimeter steel channel. Louver sections for rough openings greater than 36 in. in width shall be provided with steel blade reinforcing angles concealed from view. Louvers shall be provided with steel installation anchor plates, which are required at the head (top) and sill (bottom) only. Ship loose or site installed additional structural supports shall not be accepted for either single section assemblies or multiple louver sections within an opening wider than 60 1/2 inches. Louver performance data shall be licensed under the AMCA Certified Rating Program and shall bear the AMCA Certified Ratings Seal. This certified performance data shall include airflow pressure loss and water penetration, and shall demonstrate performance equal to or better than the Greenheck model specified.

Application of any louver involves selecting an airflow velocity through the louver free area (free area velocity in fpm) that produces an acceptable pressure drop and for intake applications minimizes carry through of normally encountered rain water.

No louver manufacturer warrants their louver to prevent water penetration under all possible combinations of wind and rain. Water penetration through Model ESD-603D begins at 1232 fpm free area velocity. Intake air louver selection using free area velocity below 1232 fpm is recommended. Louver selection involves the following two steps, and depending on given conditions, either step may come first.

Select Free Area Velocity:

Using the **Airflow Resistance Chart**, select a free area velocity that produces an acceptable pressure drop with minimal water penetration. (Water penetration need not be considered when selecting exhaust louvers.)

Determine Louver Free Area:

Using the free area velocity from previous step and total cfm, determine Louver Free Area required. Using the **Louver Free Area Chart**, select a louver with the required free area. If louver size is given, determine free area from chart and work backwards to determine maximum airflow. See examples below.

Free Area Chart ESD-603D Rough Opening Dimensions

R.O. Height Inches	Rough Opening Width in Inches																R.O. Height Inches	
	12.5	15.5	18.5	21.5	24.5	27.5	30.5	33.5	36.5	39.5	42.5	45.5	48.5	51.5	54.5	57.5		60.5
	Nominal Louver Width in Inches (1/2 in. less than rough opening size)																	
	12	15	18	21	24	27	30	33	36	39	42	45	48	51	54	57	60	
15	0.27	0.36	0.45	0.54	0.63	0.72	0.80	0.89	0.98	1.03	1.11	1.20	1.29	1.38	1.47	1.56	1.65	15
18	0.44	0.59	0.73	0.88	1.02	1.16	1.31	1.45	1.60	1.67	1.81	1.96	2.10	2.24	2.39	2.53	2.68	18
24	0.70	0.93	1.15	1.38	1.61	1.84	2.06	2.29	2.52	2.63	2.86	3.08	3.31	3.54	3.77	3.99	4.22	24
30	0.96	1.27	1.58	1.89	2.20	2.51	2.82	3.13	3.44	3.59	3.90	4.21	4.52	4.83	5.14	5.45	5.76	30
36	1.21	1.60	2.00	2.39	2.78	3.17	3.57	3.96	4.35	4.55	4.94	5.33	5.73	6.12	6.51	6.90	7.30	36
42	1.37	1.81	2.25	2.70	3.14	3.59	4.03	4.47	4.92	5.14	5.58	6.03	6.47	6.91	7.36	7.80	8.24	42
48	1.62	2.15	2.67	3.20	3.73	4.25	4.78	5.30	5.83	6.09	6.62	7.15	7.67	8.20	8.72	9.25	9.78	48
54	1.87	2.48	3.09	3.69	4.30	4.91	5.52	6.12	6.73	7.03	7.64	8.25	8.86	9.46	10.07	10.68	11.28	54
60	2.12	2.81	3.50	4.19	4.88	5.56	6.25	6.94	7.63	7.97	8.66	9.35	10.04	10.73	11.42	12.10	12.79	60
66	2.38	3.15	3.92	4.69	5.46	6.23	7.00	7.77	8.54	8.93	9.70	10.47	11.24	12.01	12.78	13.55	14.32	66
72	2.63	3.48	4.34	5.19	6.04	6.90	7.75	8.60	9.46	9.88	10.74	11.59	12.44	13.30	14.15	15.00	15.85	72
78	2.89	3.82	4.76	5.69	6.63	7.57	8.50	9.44	10.37	10.84	11.78	12.71	13.65	14.59	15.52	16.46	17.39	78
84	3.14	4.16	5.18	6.20	7.22	8.24	9.26	10.27	11.29	11.80	12.82	13.84	14.86	15.88	16.90	17.92	18.94	84
90	3.40	4.50	5.60	6.70	7.81	8.91	10.01	11.11	12.21	12.77	13.87	14.97	16.07	17.17	18.28	19.38	20.48	90
96	3.65	4.84	6.02	7.21	8.40	9.58	10.77	11.95	13.14	13.73	14.91	16.10	17.28	18.47	19.65	20.84	22.02	96
102	3.91	5.18	6.44	7.71	8.98	10.25	11.51	12.78	14.05	14.68	15.95	17.22	18.49	19.75	21.02	22.29	23.56	102
108	4.07	5.38	6.70	8.02	9.34	10.66	11.98	13.30	14.61	15.27	16.59	17.91	19.23	20.55	21.87	23.18	24.50	108
114	4.32	5.72	7.12	8.52	9.92	11.33	12.73	14.13	15.53	16.23	17.63	19.03	20.43	21.83	23.23	24.63	26.04	114
120	4.57	6.05	7.53	9.02	10.50	11.98	13.46	14.95	16.43	17.17	18.65	20.13	21.62	23.10	24.58	26.06	27.54	120

Louver Free Area In Square Feet

ESD-603D Selection and Examples

Example 1:

Airflow given as 10,000 cfm – select louver size.

- A. Determine louver free area by dividing airflow by free area velocity (do not exceed 1232 fpm on intake louver application).

$$\frac{10,000 \text{ cfm}}{\text{Airflow}} \div \frac{1232 \text{ fpm}}{\text{Free Area Velocity}} = \frac{8.12 \text{ ft.}^2}{\text{Required Louver Free Area}}$$

- B. Select a louver with at least the required louver free area from **Free Area Chart** above. Rough Opening =

$$\frac{60.5 \text{ in.}}{8.24 \text{ ft.}^2 \text{ free area}} \times \frac{42 \text{ in.}}{8.24 \text{ ft.}^2 \text{ free area}} = \text{H}$$

$$\frac{1214 \text{ fpm free area velocity (10,000 cfm} \div 8.24 \text{ ft.}^2 \text{ F.A.)}}{\text{Free Area Velocity}} = \text{H}$$

(Other selections available – See **Free Area Chart** above.)

- C. Check the pressure drop of the selected louver at the given airflow (**Airflow Resistance Chart** on Page 2).

$$\Delta P \text{ at } \frac{1214 \text{ fpm}}{\text{Free Area Velocity}} = \frac{0.30 \text{ in. wg}}{\text{Pressure Drop}}$$

Example 2:

Louver rough opening size given as 48.5 x 48 – determine maximum intake airflow.

- A. Use **Free Area Chart** to determine Free Area = 7.67 ft.²

- B. Multiply Free Area x Free Area Velocity (Do not exceed 1232 fpm on intake louver applications).

$$\frac{7.67 \text{ ft.}^2}{\text{Free Area}} \times \frac{1232 \text{ fpm}}{\text{Free Area Velocity}} = \frac{9,449 \text{ cfm}}{\text{Maximum Airflow}}$$

- C. Check the pressure drop of the selected louver at the given airflow (**Airflow Resistance Chart** on Page 2).

$$\Delta P \text{ at } \frac{1232 \text{ fpm}}{\text{Free Area Velocity}} = \frac{0.31 \text{ in. wg}}{\text{Pressure Drop}}$$

INSTALLATION INFORMATION

Steel Framed Installation

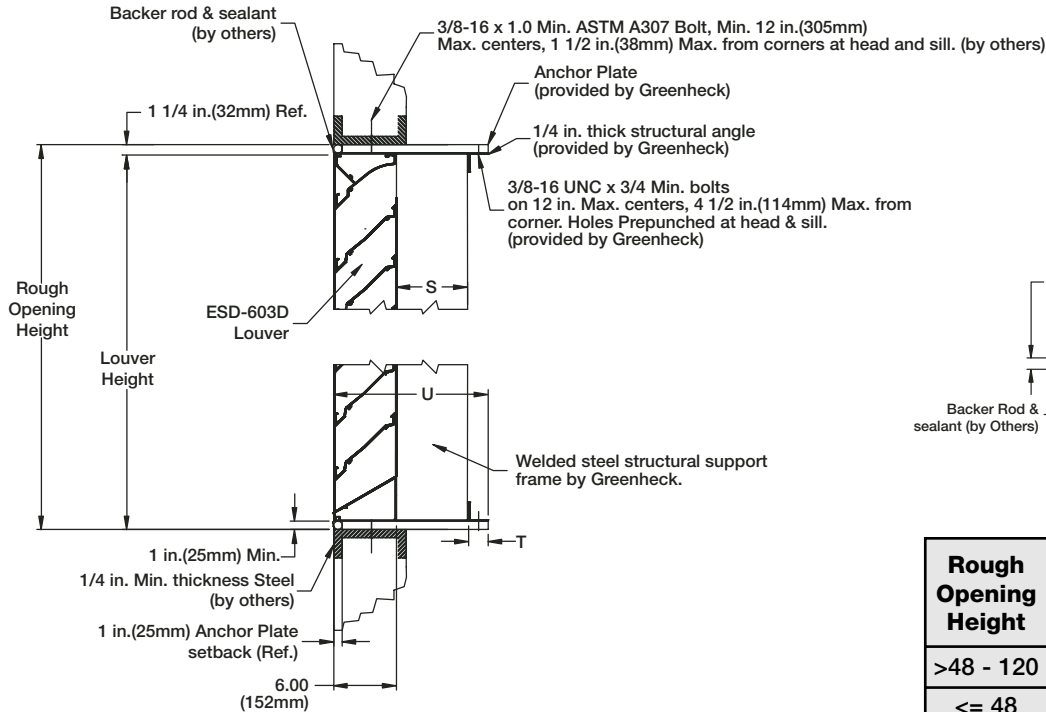

Jamb Detail

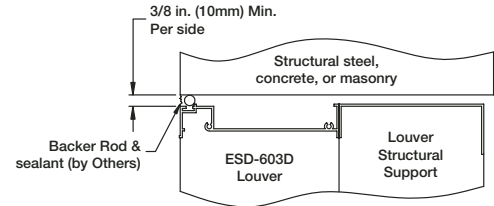

Rough Opening Height	"S"	"T"	Overall Depth (Ref.) "U"
>48 - 120	7 in.	2 in.	15.125 in.
<= 48	3 in.	2 in.	11.125 in.

Concrete or Masonry Opening Installation

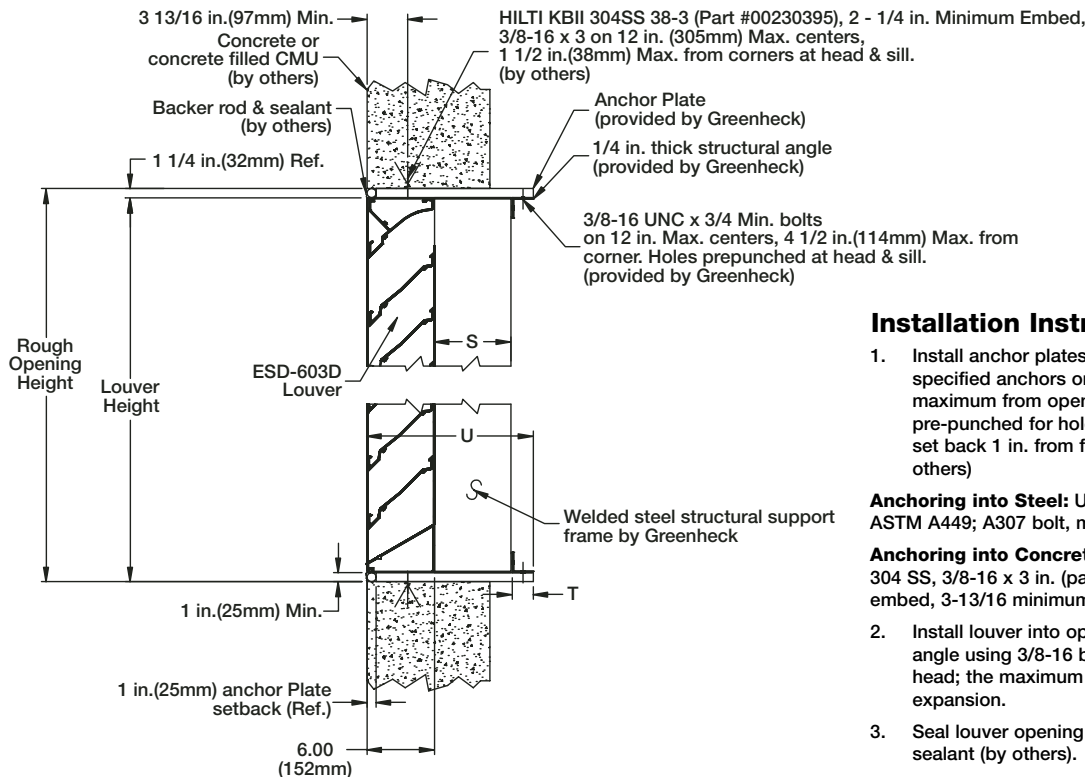

Installation Instructions

1. Install anchor plates at opening head and sill using specified anchors on maximum 12 in. center, 1 1/2 in. maximum from opening corners. Anchor plates are pre-punched for hole locations. Front edge of plate is set back 1 in. from front edge of louver. (Fasteners by others)

Anchoring into Steel: Use 3/8-16 x 1.0 minimum length ASTM A449; A307 bolt, minimum.

Anchoring into Concrete or Masonry: Use Hilti KBII type 304 SS, 3/8-16 x 3 in. (part #00230395), 2-1/4 in. minimum embed, 3-13/16 minimum edge distance.

2. Install louver into opening. Fasten anchor plates to rear angle using 3/8-16 bolts provided. Do not shim at head; the maximum 1/4 in. clearance is for thermal expansion.
3. Seal louver opening to perimeter using backer rod and sealant (by others).



P.O. Box 410 • Schofield, WI 54476-0410 • 715.359.6171 • greenheck.com

Submittal-ESD-603D Metro-Dade FS
Rev. 2 December 2005
Copyright © 2005 Greenheck Fan Corp.