

REDGARD® WATERPROOFING AND CRACK PREVENTION MEMBRANE

- **Convenient – ready to use**
- **Apply by roller, trowel or sprayer**
- **Listed with IAPMO for use as a shower pan liner**
- **Elastomeric – Isolates cracks up to 1/8" (3 mm)**

PRICE



PRODUCT DESCRIPTION

Ready-to-use, elastomeric, waterproofing and crack prevention membrane for all interior or exterior commercial and residential tile and stone installations. Easily applied with roller, trowel or sprayer producing a continuous moisture barrier with outstanding adhesion. Reduces crack transmission in ceramic tile or stone floors. Meets ANSI A118.10 for waterproofing membranes and ANSI A118.12 for crack isolation membranes. Meets Uniform Plumbing Code specifications for use as a shower pan liner. Listed with IAPMO R & T, File #4244 UPC®. ICC-ES ER-6014. Can also be used as a slab-on-grade moisture barrier under resilient flooring. For instructions for use as a slab-on-grade moisture barrier for resilient flooring installations, refer to Custom's technical bulletin Installation Instructions for E-Cap™ Moisture Barrier System.

AREAS OF USE

- Concrete
- Cement backerboards, WonderBoard®
- Exterior grade plywood (interior, dry areas for crack isolation only)
- Exterior decks
- Gypsum drywall

LIMITATIONS

- Do not apply to surfaces that may go below 40° F (4° C) during the first 72 hours after application, over wet surfaces or surfaces subject to hydrostatic pressure.
- Do not use to bridge or cover over existing expansion, control, construction, cold or saw-cut joints.
- Not for use as an adhesive.
- Do not use as a wear surface. Membrane must be covered with tile.

SURFACE PREPARATION

All exterior and wet areas are to have proper sloping to drains. All surfaces must be structurally sound, clean, dry and free from contaminants that would prevent a good bond. Newly prepared concrete must be cured 28 days, finished with a steel trowel and have a fine broom finish. Existing surfaces should be scarified, level and all defects repaired. Cracks in excess of 1/8" (3 mm) should be treated as expansion joints.

APPLICATION

As a Crack Prevention Membrane:

Force RedGard into cracks with the flat side of the trowel, roller or brush. Then, using a 3/16" x 1/4" (5 x 6 mm) V-notch trowel or 3/8" (9.5 mm) rough textured roller, apply additional material onto the substrate. If using a trowel, use the flat side of the trowel and flatten the ridges to form a continuous, even coat of material. Membrane should extend beyond both sides of the crack a minimum of the diagonal measurement of the tile. Gaps between plywood sheets and where they meet walls should also be pre-filled with membrane. For continuous crack isolation cover the entire substrate with material. Material should be applied at least 30 mils wet film thickness.

As a Waterproof Membrane:

All cracks in concrete up to 1/8" (3 mm) should be pre-filled with membrane prior to application. Dampen all porous surfaces. Use a 3/4" (19 mm) rough textured synthetic roller, or a 3/16" x 1/4" (5 x 6 mm) V-notch trowel. Heavily pre-coat corners and where floors and walls meet extending it 6" (15 cm) on either side. For exterior change of plane embed 6" (15 cm) wide fiberglass mesh into the membrane in corners and where floors and walls meet. If using a trowel, spread the material with trowel held at a 45° angle then flatten the ridges. If using a roller, apply a continuous, even film with overlapping strokes. Alternatively, an airless sprayer can be used. The sprayer should produce between 1900 to 2300 psi, with a flow



CUSTOM®
BUILDING PRODUCTS

rate of 1.0 to 1.5 gpm and have a tip orifice size of .025 to .029. Apply a continuous film with overlapping spray. Initial membrane appearance is pink when wet and dries to a dark red color. After the first coat has turned red with no blushing or light pink showing, about 1-1/2 to 2 hours, visually inspect the film for integrity and fill any voids or pinholes with additional material and apply a second coat at right angles to the first. Periodically check film thickness with a wet film gauge. The combined dried coating needs to be a minimum of 47 mils thick or 93 mils when wet and should not exceed 125 mils wet film thickness.

Interior Change of Plane — Commercial Installations:

Many commercial waterproofing installations require reinforcing of interior change of plane. Contact Technical Support prior to beginning any commercial installation for review and recommendations. These installations include, but are not limited to, the following:

- All above grade pools, fountains and other poured in place or free standing structures that will be required to hold water permanently.
- All commercial floors that are subject to continuous water exposure (i.e. commercial kitchens, wash downs, periodic flooding, etc.)
- All above grade slabs that are either pre-stressed or post tensioned.
- All perimeters where the floor abuts a curtain or shear wall.
- Around the perimeter of all through floor penetrations (i.e. drain pipes, electrical conduit, etc.)

Expansion Joints

Do not bridge joints which are designed to experience movement. Carry these types of joints through the tilework. Clean the joint and install open or closed cell backer rod to the proper depth as outlined in EJ 171 in the Tile Council Handbook. Next, compress a sealant as specified by the architect into the joint, coating the sides and leaving it flush with the surface. After the sealant is dry, place bond breaker tape over joint. Apply a minimum 3/64" (1.2 mm) of RedGuard over the joint and substrate following the instructions detailed in APPLICATION. Install the tile work onto the membrane but do not bridge the joint. After the tile work is set properly, fill the joint with any specified color sealant, following the architect's and manufacturer's instructions.

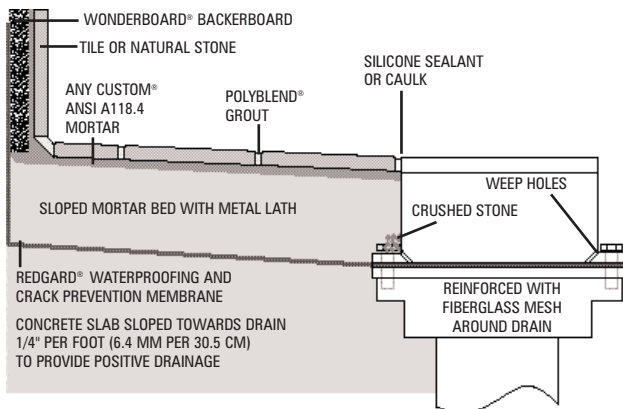

Drains:

Drains should have a clamping ring with open weep holes for thin-set application. Apply membrane to the bottom flange. Drain should be fully supported without movement and even with plane of substrate. Apply membrane as outlined under APPLICATION. Embed 12" x 12" (30 x 30 cm) fiberglass mesh into membrane making sure it does not obstruct the drainage hole. Then apply an additional coat of membrane and smooth. After curing, clamp upper flange onto membrane and tighten. Caulk around flange where membrane and upper flange make contact with a silicone caulk. A toilet flange can be handled in much the same manner.

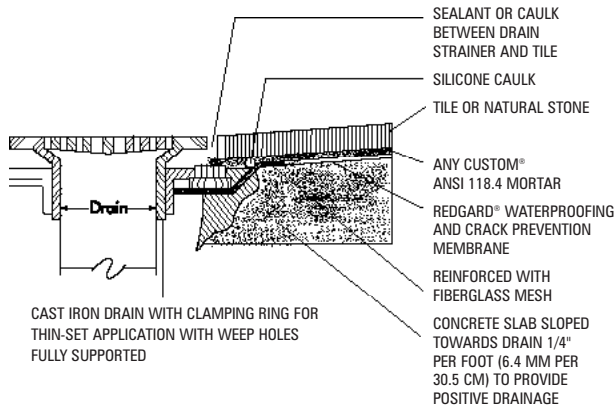

PROTECTION

If tile is not going to be set immediately after curing, RedGuard should be protected from rain, direct sunlight and inclement weather for 72 hours after application. If delays longer than 72 hours are expected, cover with felt paper. Care should be taken to prevent membrane from becoming soiled or punctured during and after application.

TILE INSTALLATION

Install tile or stone with a Custom® polymer-modified mortar meeting ANSI A118.4 or A118.11 standards.

CURING

The product is dry when it turns solid red with no pink showing, normally 1-1/2 to 2 hours. Depending on ambient conditions, drying time can take up to 12 hours. A water test can be conducted 72 hours after application if required.

CLEAN-UP

Clean tools and hands with water before material dries. Clean all spray equipment immediately after use.

COVERAGE

As a Crack Prevention Membrane

1 gallon (3.78 L) pail: 110 sq. ft. (10.2 M²)
at 30 mil thickness when wet

5 gallon (18.9 L) pail: 550 sq. ft. (51 M²)
at 30 mil thickness when wet

As a Waterproof Membrane

1 gallon (3.78 L) pail: 35 - 40 sq. ft. (3.25 - 3.7 M²)
at 93 mil thickness when wet, 47 mils dry

5 gallon (18.9 L) pail: 175 - 200 sq. ft. (16.2 - 18.5 M²)
at 93 mil thickness when wet, 47 mils dry

STORAGE

Keep from freezing.

SAFETY

Wear rubber gloves and eye protection. Avoid eye contact. If eye contact occurs, flush with water for 15 minutes and call a physician. Wash thoroughly after handling.

KEEP OUT OF REACH OF CHILDREN.

DO NOT TAKE INTERNALLY.

ORDERING INFORMATION

	ITEM CODE	SIZE	COLOR	PACKAGE
USA	LQWAF1	1 gallon (3.78 L)	Pink	Pail
USA	LQWAF5	5 gallon (18.9 L)	Pink	Pail
Canada	CLQWAF1	1 gallon (3.78 L)	Pink	Pail

TECHNICAL DATA

Meets ANSI A118.10 for load-bearing, bonded, waterproof membranes for thin-set ceramic tile and dimensional stone installations. Meets ANSI A118.12 for crack isolation membranes. Meets Uniform Plumbing Code specifications for use as a shower pan liner. Listed with IAPMO R & T, File #4244 UPC®. ICC-ES ER-6014.

	REDGARD® WATERPROOFING AND CRACK PREVENTION MEMBRANE
Pot Life	Indefinite
Initial Set, ASTM C191 @ 70° F (21° C)	1 1/2 - 2
Drying time before tile installation	1 1/2 - 2 hours or up to 12 hours
ANSI 118.10 Sect. #	
Fungus and Micro-Organism Resistance (4.2)	Passes
Seam Strength (4.2)	16 lbs./2 inch width (>7.3 kg/5 cm)
Breaking Strength (4.3)	484 psi (34.0 kg/cm ²)
Dimensional Stability (4.4)	0.05%
Waterproofness (4.5)	Passes
Shear Strength	
12-week dry cure (5.6)	267 psi (18.8 kg/cm ²)
100-day water immersion (5.7)	89 psi (6.3 kg/cm ²)
% Elongation ASTM D-638	
21-day dry cure	562%
7-day dry cure / 21-day wet cure	657%
Robinson Floor Test ASTM C627	14 cycles Extra heavy rating
IAPMO/Uniform Plumbing Code #4244	
Hydrostatic pressure & alkali resistance	Passes
Waterproofness	Passes
FHA 4900-1-615-5, Sections C & D	Compliant
Permeance Rating	0.06
Water Vapor Transmission	0.02 (grains/hr-sq ft)

Conforms to Wisconsin's performance requirements for "safing material" as required by s. Comm 84.30 (6)(f) of the Wisconsin Administrative Code.

WARRANTY

Eligible for Custom's Lifetime Installations Systems Warranty. For complete information call 800-272-8786 or visit www.custombuildingproducts.com.



CUSTOM
BUILDING PRODUCTS