



The
POWER *In*
PRESENTATION PRODUCTS



REAR PROJECTION SCREENS

PLANNING REAR PROJECTION INSTALLATIONS

Determine the Screen Size:

- Screen height should be at least $\frac{1}{6}$ the distance from the screen to the last row of seats, allowing text to be read and detail to be seen in the projected image.
- The bottom of the screen should be a minimum of 4 feet above the audience floor, allowing those seated toward the rear to see the screen.

Determine the Optical Coating Or Choose The Profiled Screen:

Optical Coatings:

- Video Vision, 1.0 gain, 55° half angle
- DA-100, 1.0 gain, 35° half angle
- DA-130, 1.3 gain, 34° half angle
- DA-150, 1.5 gain, 32° half angle
- DA-180, 1.8 gain, 30° half angle
- DA-230, 2.3 gain, 25° half angle
- DA-75WA, 0.75 gain, 78° half angle
- DA-100WA, 1.0 gain, 52° half angle

Profiled Screens:

- Da-View
- Data Pro

Screen Orientation:

- The screen should always be installed with the optical coating toward the audience.
- The matte finish of the coating prevents distracting reflections on the screen.
- The vulnerability of the surface is reduced by Protek II which is included on Da-Plex and Da-Glas.

Complete Mirror System Design Service:

Da Lite's technical staff is trained to assist with the overall design by producing a drawing of each mirror system set up.

Customers wishing to utilize this service need to answer the following questions:

1. Projector Make: _____
2. Projector Model: _____
3. Special Considerations (custom lens, etc.): _____
4. Angle of Projection Axis: ____ Normal (0 degrees); _____ degrees Below normal; _____ degrees Above normal
The Normal assumes the center most light ray will pass through the screen perpendicular to screen center.
5. Any variation from a zero degree entrance angle should be indicated (Above/Below) _____
6. What is the screen's viewing area (H x W)? _____
7. What is the height from the bottom of the screen's viewing area to the floor? _____
8. What is the depth of the projection room? _____
9. What is the height of the projection room? _____
10. What is the width of the projection room? _____
11. What is the thickness of the wall in which the screen is placed? _____
12. What is the screen type? _____
13. How far is the back of the screen offset from the back of the wall it is set in? _____
14. What is the frame type? _____
15. What is the distance to the first row? _____
16. What is the distance to the back row? _____
17. How many risers are there? _____
18. How high is each riser? _____
19. Is this an edge blending application? _____
 - a. What is the projector's resolution? _____
 - b. What is the amount of overlap? _____

With this data, Da-Lite's experienced technicians will calculate the correct placement and dimensions of the mirror rack. The drawings will also indicate the angle at which each mirror is to be tilted. Upon delivery of the system, a detailed drawing will be provided indicating all components of the system and assembly instructions.

Specification Requirements For The Right Rear Projection Screen:

Determine whether a diffusion or profiled screen is optimal.

A. Diffusion Screens (Da-Plex, Da-Glas)

1. Determine the ideal optical coating
2. Determine the base material
3. Determine the framing method (optional)
4. Determine if high contrast tint is needed (optional)
5. Determine size required

B. Profiled Screens (Da-View)

1. Determine the screen properties that best meet your requirements
2. Determine the size required
3. Determine the framing method (optional)

Ten Reasons To Choose Da-Lite Rear Projections Screens:

1. Superior resolution, uniformity and color fidelity
2. Proven quality record: inspection of every screen
3. On-time shipment
4. Unique insurance program against shipping damage.
5. Protective shipping crates
6. A dedicated facility with an unparalleled reputation
7. Ten-year warranty
8. Unsurpassed size and choice selection
9. Custom design welcome
10. Superior technical support

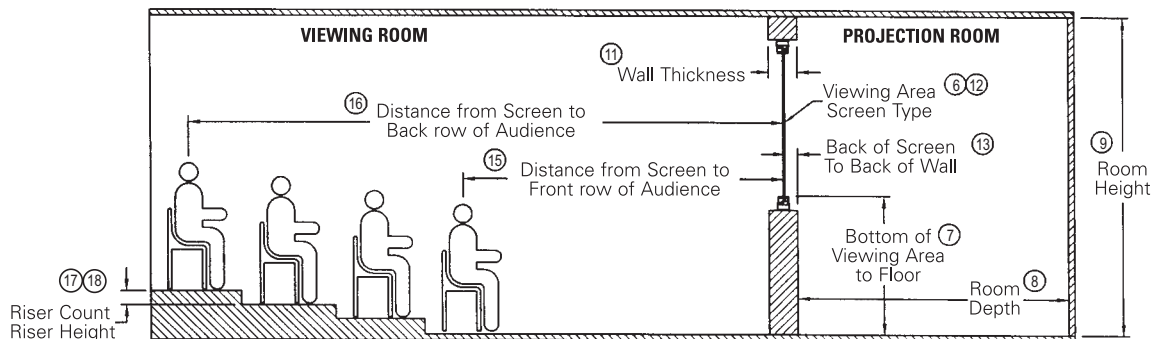

POLACOAT® HIGH RESOLUTION DIFFUSION SCREENS

Specifying Da-Lite's Polacoat® Rear Projection Screens:

Da-Plex

- Acrylic base for breakage resistance, lightweight, high optical quality, ease of handling and superior transmission.
- In standard sizes up to 9' x 18' outside dimension.

Note:

Wider sizes available upon request.

Da-Glas

- Glass provides flat, rigid base for long service life, maximum sound isolation and structural strength.
- In standard sizes up to 10' x 20' outside dimension.

Note:

Wider sizes available upon request.

	Da-Plex	Da-Glas
Standard Size Selection Up To*	9' x 18'	10' x 20'
Indoor Service Life	Indefinite	Indefinite
Noise Isolation	Excellent	Excellent
Scratch Resistance	Excellent	Excellent
Cleaning Method	Mild Soap and Water	Mild Soap and Water
Cleaning Frequency	As Required	As Required
Break Resistance	Excellent	Good
Weight	Lighter	Heavier
Thicknesses	1/4", 3/8", 1/2"	1/4", 3/8", 1/2"

*Note: Wider sizes available upon request.

Protek II®

Da-Lite's Polacoat screens are standard with a factory applied protective coating to minimize the possibility of accidental surface damage. Protek II is a very abrasion resistant coating applied to the diffusion coating to minimize accidental surface damage. Incidental contact with markers to the surface can be removed if done quickly with denatured alcohol.

OPTIONAL TINT

High Contrast Tint

This feature can significantly enhance the perceived quality of video images. By making the dark elements of an image appear even darker, perceived contrast is increased.

Note: Cannot be used with Video Vision coating.

Maintenance:

Da-Lite Rear Projection Screens, glass or acrylic, are designed for long, useful life. Properly installed and cared for, they will produce high quality images for many years. Listed below are recommended methods to clean, handle and repair optical panels. Repair of damage not described herein should be discussed with our Sales Partners. Liability and risk in cleaning or repairing rear projection screens are assumed by the user.

Cleaning:

- Da-Lite Lensklean Cleaner is especially formulated to clean Da-Lite's Polacoat® rear projection screens.
- Remove dust by gently washing the screen with a soft cloth and mild solution of dish washing liquid and water. Rinse with clear water and blot dry.
- Do not use abrasive cleaning agents, solvents, commercial cleaners or ammonia cleaning solutions.

Repair:

- Slight scuffs and scratches on screens may be removed by cleaning the area thoroughly with mild soap and water.

Handling:

- Upon receipt of crates, inspect immediately for concealed damage.
- Keep screens in shipping cartons until used. Store in a dry area between 40°F and 100°F.
- Screens, cartons and crates should always be stored and handled in an upright position. Never lean or stack them flat.
- Cotton gloves are recommended for safe handling. Handle screens by edges.
- Installation locations should always be clean and free of any objects or solvents which could fall onto the surface of the screen.

OPTICAL DIFFUSION COATINGS

Video Vision:

A special neutral white coating process produces a unity gain screen which is ideal for video projection under controlled light conditions. With an exceptionally wide viewing cone, each seat in the audience will observe a uniform, bright, sharp, image with even color response.

DA-100:

The DA-100 coating is neutral gray in appearance and produces an on-axis gain of 1. This is the most uniform of all diffusion screens with contrast enhancement. This gain is particularly suited to high-resolution applications. DA-100 offers a 35° half angle.

DA-130:

The DA-130 coating is neutral gray in appearance and produces a 1.3 on axis gain and a 34° half angle. This coating is best suited in applications requiring moderate gain and viewing angles.

DA-150:

A neutral gray screen offering an on-axis gain of 1.5, the DA-150 is a surface well suited for applications whose viewing angles are not large but which can benefit from moderate screen gain. DA-150 has a 32° half angle.

DA-180:

The neutral gray DA-180 screen's center gain is 1.8. This is a particularly good surface when reduced viewing angles can allow for a higher gain performance. The half angle of the DA-180 is approximately 30° with a generous viewing cone of 60°.

DA-230:

The DA-230 is a 2.3 gain, neutral gray screen. This screen's half angle is approximately 25° with a viewing cone of approximately 50°. Because of its higher gain, the DA-230 can successfully compete with larger amounts of ambient room light than lower gain screens.

WIDE ANGLE POLACOAT® OPTICAL COATINGS

DA-75 WA

A light gray diffusion coating with a .75 gain and 78° half angle. DA-75 WA is designed for use in applications where a short throw lens is required. Due to the increased half angles, DA-75 WA performs well with wide format screens. From the viewer's perspective, side-to-side uniformity of the screen is maximized. Ideal for edge blending applications.

DA-100 WA

A light gray diffusion coating that provides a unity gain and 52° half angle. This wide angle optical coating is designed for use in applications where a short throw lens is required. Due to the increased half angles, DA-100 WA performs well with wide format screens. From the viewer's perspective, side-to-side uniformity of the screen is maximized. Ideal for edge blending applications.

Note: Custom gain screens available upon request.

DA-PLEX



Suggested Specifications:

Da-Lite's Polacoat® Da-Plex In-Wall Rear Projection Screens

Rear projection screens shall be Da-Lite's Polacoat® In-Wall Da-Plex, Type DA-100, DA-130, DA-150, DA-180, DA-230, DA-75WA, DA-100WA or Video Vision in thickness of 1/4", 3/8" or 1/2" as manufactured by Da-Lite Screen Company, Inc., Polacoat® Division, Blue Ash, Ohio. The screen substrate shall be clear acrylic plastic. The substrate shall have an optical coating on one surface not exceeding .004" in thickness. The overall size of the acrylic panels shall be as detailed ±.125" for 1/4", ±.250" for 3/8" or ±.375" for 1/2".

Notes:

Da-Plex rear projection screens shall be mounted with the coated surface toward the audience. Job site installation and framing shall conform to manufacturer's recommendations.

Optional Extras:

- High Contrast Tint
- Factory-mounted aluminum frame
- Anti-glare Coating

Screens Without Frames:

- Screens can be ordered without frames and framed on site with wood, plastic or metal.
- Large Da-Plex screens should be installed so weight is suspended from the top.
- All construction, painting and finishing should be completed before installation to reduce the chance of damage to the optical surface.
- It is recommended that installation of unframed screens be handled by experienced glaziers.
- Installation guidelines accompany each screen.
- Expansion and contraction allowance should be planned in installation.

Custom Sizes:

- Da-Plex and Da-Glas screens are available in a wide range of custom sizes.
- Screens over 8-feet high require the use of a special contract freight carrier.

Butt Edges:

When a multiple screen installation is chosen, it is required that the surface butt edges be custom prepared. This is a special process. Contact our Sales Partners for complete information.

Sizes and Tolerances:

Da-Lite's Polacoat® rear projection screens are made to the exact dimensions requested by the purchaser plus or minus (±) the following standard tolerances. The user must allow for any space between the screen and the opening that would be required for proper mounting.

Thickness	Da-Plex
1/4"	± .125"
3/8"	± .250"
1/2"	± .375"

DA-PLEX VIDEO FORMAT

Viewing Area HxW	Nominal Diagonal	Unframed	Base	Standard	Deluxe	Self-Trimming
36"x48"	60"	X	X	X	X	X
40 1/4"x53 1/4"	67"	X	X	X	X	X
43 1/4"x57 3/4"	72"	X	X	X	X	X
50 1/2"x67 1/4"	84"	X	X	X	X	X
57 3/4"x77"	96"	X	X	X	X	X
60"x80"	100"	X	X	X	X	X
72"x96"	120"	X		X	X	X
81"x108"	135"	X		X	X	X
90"x120"	150"	X		X	X	X
99"x132"	165"	X		X	X	X
108"x144"	180"	X			X	

DA-PLEX HDTV FORMAT

Viewing Area HxW	Nominal Diagonal	Unframed	Base	Standard	Deluxe	Self-Trimming
40 1/2"x72"	82"	X	X	X	X	X
45"x80"	92"	X	X	X	X	X
52"x92"	106"	X	X	X	X	X
58"x104"	119"	X		X	X	X
65"x116"	133"	X		X	X	X
78"x139"	159"	X		X	X	X
94 1/2"x168"	193"	X		X	X	X

DA-PLEX SQUARE FORMAT

Size HxW	Unframed	Base	Standard	Deluxe	Self-Trimming
50"x50"	X	X	X	X	X
60"x60"	X	X	X	X	X
70"x70"	X	X	X	X	X
84"x84"	X		X	X	X
96"x96"	X		X	X	X
96"x120"	X		X	X	X
108"x108"	X			X	

DA-GLAS



Suggested Specifications:

Da-Lite's Polacoat® Da-Glas In-Wall Rear Projection Screens

Rear projection screens shall be Da-Lite's Polacoat® In-Wall Da-Glas, Type DA-100, DA-130, DA-150, DA-180, DA-230, DA-75WA, DA-100WA or Video Vision in thickness of 1/4", 3/8" or 1/2" as manufactured by Da-Lite Screen Company, Inc., Polacoat® Division, Blue Ash, Ohio. The screen substrate shall be clear float glass. The substrate shall have an optical coating on one surface not exceeding .004" in thickness. The height and width dimensions shall be as detailed with tolerances of ±.125" for 1/4", ±.250" for 3/8" or ±.375" for 1/2".

Notes:

Da-Glas rear projection screens shall be mounted with the coated surface toward the audience. Job site installation and framing shall conform to manufacturer's recommendations.

Optional Extras:

- High Contrast Tint
- Factory-mounted aluminum frame
- Anti-glare Coating

Screens Without Frames:

- Screens can be ordered without frames and framed on site with wood, plastic or metal.
- All construction, painting and finishing should be completed before installation to reduce the chance of damage to the optical surface.
- It is recommended that installation of unframed screens be handled by experienced glaziers.
- Installation guidelines accompany each screen.

Custom Sizes:

- Da-Plex and Da-Glas screens are available in a wide range of custom sizes.
- Screens over 8-feet high require the use of a special contract freight carrier.

Butt Edges:

When a multiple screen installation is chosen, it is required that the surface butt edges be custom prepared. This is a special process. Contact our Sales Partners for complete information.

Sizes and Tolerances:

Da-Lite's Polacoat® rear projection screens are made to the exact dimensions requested by the purchaser plus or minus (±) the following standard tolerances. The user must allow for any space between the screen and the opening that would be required for proper mounting.

Thickness	Da-Glas
1/4"	± .125"
3/8"	± .250"
1/2"	± .375"

DA-GLAS VIDEO FORMAT

Viewing Area HxW	Nominal Diagonal	Unframed	Base	Standard	Deluxe	Self-Trimming
36"x48"	60"	X	X	X	X	X
40 1/4"x53 3/4"	67"	X	X	X	X	X
43 1/4"x57 3/4"	72"	X	X	X	X	X
50 1/2"x67 1/4"	84"	X	X	X	X	X
57 3/4"x77"	96"	X	X	X	X	X
60"x80"	100"	X	X	X	X	X
72"x96"	120"	X	X	X	X	X
81"x108"	135"	X	X	X	X	X
90"x120"	150"	X	X	X	X	X
99"x132"	165"	X	X	X	X	X
108"x144"	180"	X	X	X	X	X

DA-GLAS HDTV FORMAT

Viewing Area HxW	Nominal Diagonal	Unframed	Base	Standard	Deluxe	Self-Trimming
40 1/2"x72"	82"	X	X	X	X	X
45"x80"	92"	X	X	X	X	X
52"x92"	106"	X	X	X	X	X
58"x104"	119"	X	X	X	X	X
65"x116"	133"	X	X	X	X	X
78"x139"	159"	X	X	X	X	X
94 1/2"x168"	193"	X	X	X	X	X

DA-GLAS SQUARE FORMAT

Size HxW	Unframed	Base	Standard	Deluxe	Self-Trimming
50"x50"	X	X	X	X	X
60"x60"	X	X	X	X	X
70"x70"	X	X	X	X	X
84"x84"	X	X	X	X	X
96"x96"	X	X	X	X	X
96"x120"	X	X	X	X	X
108"x108"	X	X	X	X	X
120"x120"	X	X	X	X	X

REAR PROJECTION SCREENS

Suggested Specifications:

Da-Lite's Data Pro Projection Screens

Rear projection screens shall be Da-Lite's Data Pro as furnished by Da-Lite Screen Company, Inc., Polacoat® Division, Blue Ash, Ohio. Screen shall be single element double profile cast acrylic with the back surface comprising a Fresnel lens and the front surface exhibiting an array of lenticulations. Fresnel grooves shall have a pitch of .19 mm and the lenticulations to have a .25 mm pitch. The on-axis gain to be 1.5 and part thickness shall be a nominal 1/4". The horizontal 1/2 gain angle to be 20° and the vertical 1/2 gain angle to be 12°.

Data Pro Screen

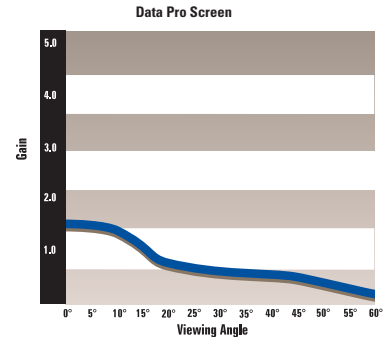
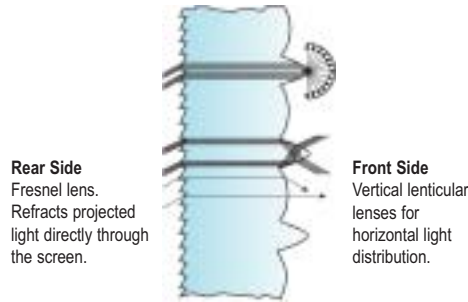

Suggested Specifications:

Da-Lite's Da-View Rear Projection Screens

Rear projection screens shall be Da-Lite's Da-View as furnished by Da-Lite Screen Company, Inc., Polacoat® Division, Blue Ash, Ohio. Screen shall be single element, double profile cast acrylic with one surface comprising a Fresnel lens and the other exhibiting an array of lenticulations. Fresnel grooves shall have pitch of 0.19 mm and the lenticulations to have a 0.25 mm pitch. On-axis gain shall be 3.5, thickness shall be 1/4".

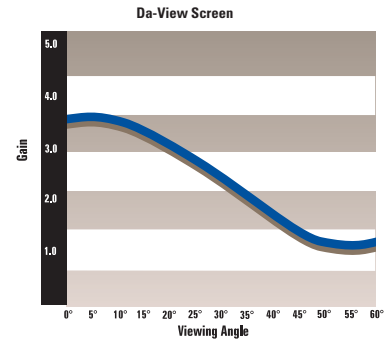
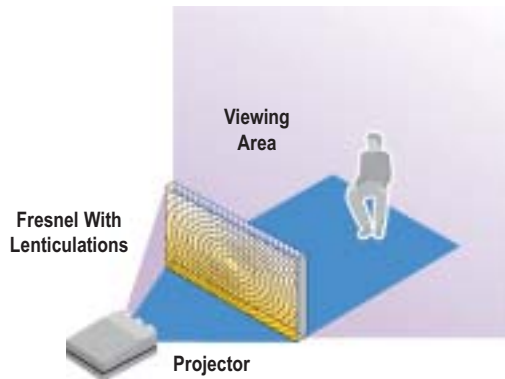

DATA PRO AND DA-VIEW VIDEO FORMATS

Viewing Area HxW	Nominal Diagonal	Unframed	Base	Standard	Deluxe	Self-Trimming
36"x48"	60"	X	X	X	X	X
40 1/4"x53 3/4"	67"	X	X	X	X	X
43 1/4"x57 3/4"	72"	X	X	X	X	X
50 1/2"x67 1/4"	84"	X	X	X	X	X
54"x72"	90"	X	X	X	X	X
57 3/4"x77"	96"	X	X	X	X	X
60"x80"	100"	X	X	X	X	X
72"x96"	120"	X	X	X	X	X
75"x100"	125"	X	X	X	X	X
81"x108"	135"	X	X	X	X	X

MAINTENANCE AND HANDLING FOR PROFILED SCREENS

Maintenance:

Da-Lite's rear projection screens are designed for a long, useful life. Properly installed and cared for, they will transmit high quality imagery for many years. Listed to the right are the recommended methods to clean and handle each of Da-Lite's screen surfaces.

Cleaning:

- To clean the front surface: Use a soft, clean cloth and Da-Lite Lenskleen. Spray or moisten the cloth and gently wipe in the direction of the lenticulations.
- DO NOT SPRAY LENSKLEEN DIRECTLY ONTO THE SCREEN'S SURFACE.
- To clean the rear surface: Use a vacuum cleaner with a clean, soft brush attachment only. Do not use liquids as over time residues may accumulate in Fresnel grooves.

Handling:

- Upon receipt of crates, inspect immediately for concealed damage.
- Store Da-Lite's screens upright in a cool, dry place. Protect from water and excessive humidity.
- Do not lean or lay flat.
- DO NOT EXPOSE TO TEMPERATURES HIGHER THAN 100°F (43°C).
- Keep screens in their shipping crates until they are installed.
- Open crates with screw driver only.
- Do not use suction cups.

REAR PROJECTION SCREENS

Suggested Specifications:

Da-Lite's Holo Screen Rear Projection Screen

Specifying Da-Lite's HoloScreen Rear Projection Screens:

HoloScreen rear projection screens from Da-Lite Screen Company, Inc. have been specifically designed for use for high ambient light and point-of-sale applications. The HoloScreen is a single piece acrylic rear projection screen with a transparent blue tint.

- The HoloScreen offers a 4.0 on-axis gain with a 28° horizontal half angle and a 22° vertical half angle.
- The HoloScreen is available in sizes up to 66" x 101".
- Custom sizes available upon request.
- Recommended projection angle of 18-35°.
- Ideal for use in point-of-sale applications.

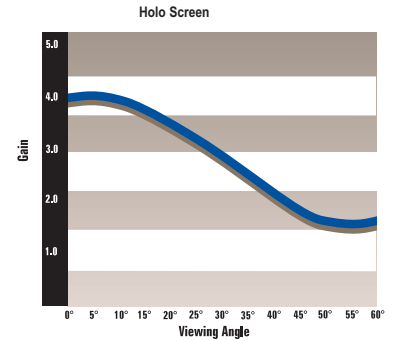
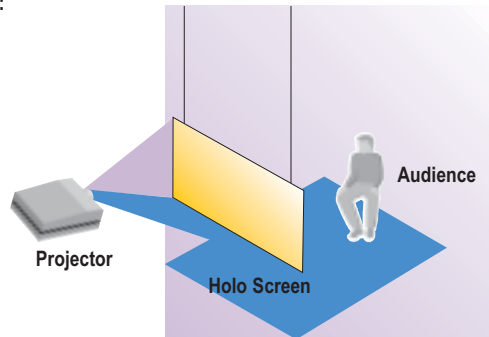

HOLO SCREEN VIDEO FORMAT

Viewing Area H x W	Framed Dimensions
22" x 33 1/4"	23 1/2" x 33 1/4"
26 3/4" x 42 1/2"	29 1/2" x 42 1/2"
33" x 50 1/2"	36" x 50 1/2"
40" x 60"	43" x 60"
47 1/4" x 69 3/4"	50 1/4" x 69 3/4"
51" x 74 1/2"	54" x 74 1/2"
55" x 84 1/4"	58" x 84 1/4"
60 1/2" x 92 3/4"	63 1/2" x 92 3/4"
66" x 101"	69" x 101"

LIGHT BAFFLES

Light baffles are ideal for use with a multiple screen application contained in a single frame.

Choose the Zero Gap Light Baffle in an edge-to-edge image application. The "wedge" shape allows the projected images to match seamlessly with virtually no visible gap between the screen panels and prevents light from one projected image from spilling over onto the screen panel beside it. To be used with Da-Plex projection screens 3/8" thick up to 60" high or 1/2" thick up to 84" high.

Choose the T-Mullion Light Baffle in an application where separate images are being projected on each screen panel and a small amount of space between each image is desired. The T-Mullion is 1" wide and features a flat black finish. To be used with rigid rear projection screens 1/4" thick up to 60" high, 3/8" thick up to 84" high and 1/2" thick up to 96" high.

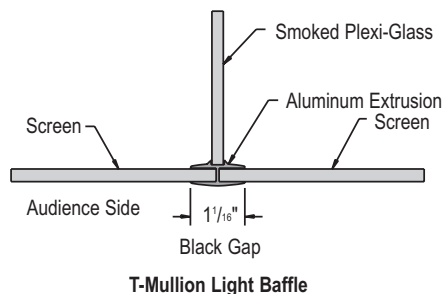
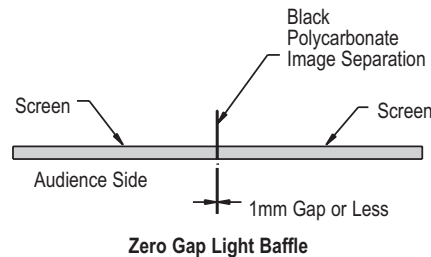

FRAMING: DELUXE AND SELF-TRIMMING

Frame Cross Section And Size Selection Information:

Da-Lite's Polacoat®, Da-Plex, Da-Glas And Da-View Screens

Factory Framed Screens:

- For installation ease, rear projection screens are available in factory frames.
- All frames are of 6063-T5 aluminum alloy with 204-A1R1 black anodized finish.
- Framed screens are shipped as a complete assembly.
- Easily installed in finished openings by carpenters, framed screens eliminate on-site glazing costs.

To Install:

1. Set screen in opening.
2. Trim out with decor matched moldings. Note: Self-Trimming Frame requires no trim-out.
3. Shim when necessary.

Select the Frame:

Deluxe Frame

- Impressive architectural design adds sophistication to every installation.
- Heavy-duty box frame construction of 2³/₄" x 3" (69.85 mm x 76 mm) rectangular dovetailed tube of .125" (3.18 mm) wall thickness is secured at the corners with self-tapping screws and mounting clips of .125" aluminum channel.
- Dovetailed design eliminates light leaks without caulking.
- Ideal for larger, heavier glass or acrylic screens in 1/2" thickness up to 10' x 20' glass and 9' x 18' acrylic.
- Available in an anodized black finish.
- Frame dimension equals viewing area plus 5¹/₂".

Self-Trimming Frame

- Self-Trimming feature eliminates the need for finish trim and makes for a fast and easy installation.
- Built-in 1¹/₂" wide finished molding to hide opening.
- Recommended for use with 1/4", 3/8" and 1/2" Da-Plex and Da-Glas in sizes up to 20' wide.
- Consult factory for larger sizes.
- Available in an anodized black finish.
- Adds 5⁷/₈" to overall viewing area.
- Frame insert size equals viewing area plus 2⁷/₈".

Specify the Size of Framed Screens:

The customer must specify overall size of the frame outside dimension (not size of opening) and must be careful to allow for the space required to fit the factory framed screen into the opening. Note: The Self-Trimming Frame's finish molding is part of the frame. Be sure to use the measurement from the edge of the frame not the edge of the finish molding when calculating the frame insert size.

Framing Detail Factory-Installed Frame:

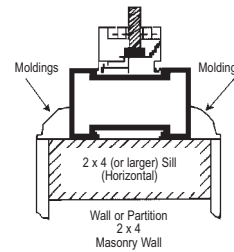

Framed Da-Lite, Da-Plex, Da-Glas and Da-View in-wall rear projection screens should be mounted in a vertical position, resting on the bottom of the frame on a suitably reinforced surface in an aperture, in a wall or partition. The unit should be shimmed and fixed in position with appropriate moldings to lock the framed panel in position.

Deluxe Frame

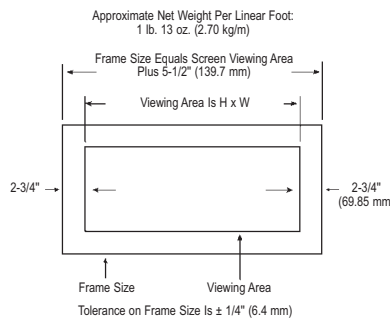
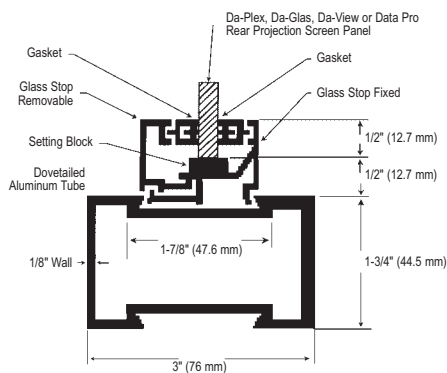

Self-Trimming Frame

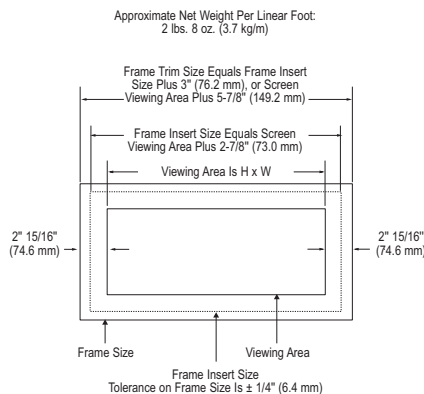
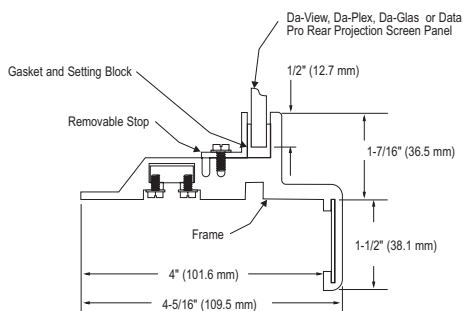

FRAMING: STANDARD AND BASE FRAMES

Frame Cross Section And Size Selection Information:

Da-Lite's Polacoat®, Da-Plex, Da-Glas And Da-View Screens

Factory Framed Screens:

- For installation ease, screens are available in factory frames.
- All frames are of 6063-T5 aluminum alloy with 204-A1R1 black anodized finish.
- Framed screens are shipped as a complete assembly.
- Easily installed in finished openings by carpenters, framed screens eliminate on-site glazing costs.

To Install:

1. Set screen in opening.
2. Trim out with decor matched moldings.
3. Shim when necessary.

Select the Frame:

Standard Frame

- Same rugged construction and design as Deluxe Frame, but 2" x 1 3/4" (50.8 mm x 45 mm).
- For screen panels up to 6' x 10' x 3/8".
- Standard factory framed screens are captured by two glass stops, centered and mounted to the base frame.
- Screens are positioned in frames with setting blocks on each screen edge and are centered between the faces of the glass stops with flexible extruded gaskets.
- Available in an anodized black finish.
- Frame dimension equals viewing area plus 4".

Base Frame

- Recommended for use with 1/4" Da-Plex and Da-View in sizes up to 6' x 8' and 1/4" Da-Glas in sizes up to 4' x 5'.
- Lightweight extruded aluminum U-channel. 23.81 mm wall thickness and weighs approximately 5 oz. per linear foot (0.142 kg/m). Secured at the corners with self-tapping screws and mounting clips.
- Mitered corners eliminate rear light leaks without caulking.
- Available in an anodized black finish.
- Frame dimensions equal viewing area plus 2 1/2".

Specify the Size of Framed Screens:

The customer must specify overall size of the frame outside dimension (not size of opening) and must be careful to allow for the space required to fit the factory framed screen into the opening.

Framing Detail Factory-Installed Frame:

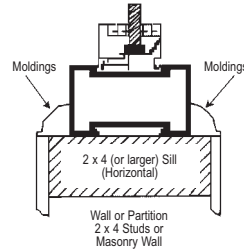

Framed Da-Lite in-wall rear projection screens should be mounted in a vertical position, resting on the bottom of the frame on a suitably reinforced surface in an aperture in a wall or partition. The unit should be shimmed and fixed in position with appropriate moldings to lock the framed panel in position.

Standard Frame

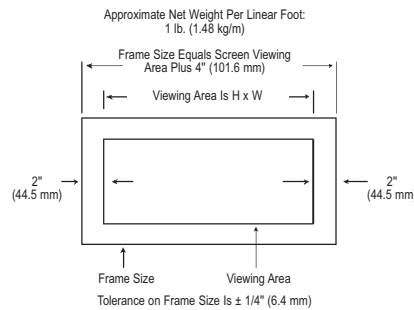
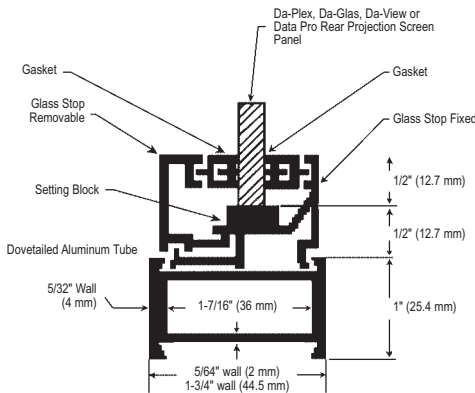

Base Frame

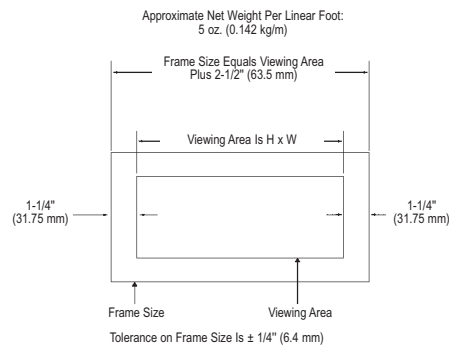
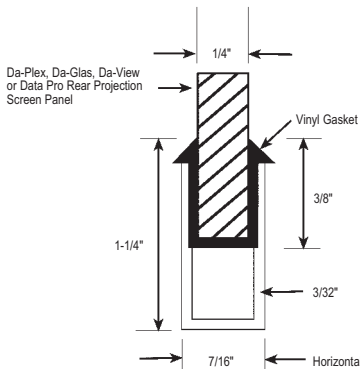

THRU-THE-WALL SYSTEM (TTW)

Thru-The-Wall (TTW) Suggested Specifications:

TTW is a component rear projection solution that comes complete with the factory framed rear projection screen of your choice with a Self-Trimming Frame and Rear Projection Module (RPM). The RPM is a precision, aluminum extrusion based rear projection module. It is designed specifically to meet the exacting requirements of newer, digital projectors, and is manufactured to precise tolerances. The RPM is used to save valuable real estate by folding the projector's light path utilizing an optical quality first surface mirror. State-of-the-Art solid modeling software is used to design the RPM.

The Rear Projection Module shall be constructed of matte black anodized 1 3/4" square aluminum extrusion. The aluminum shall be 6063-T6 Alloy with a 1/8" typical wall. The connections of the extrusion shall be die cast Zinc #3 alloy powder-coated corner blocks. All sheet metal parts shall be powder-coated steel utilizing a minimum of 14 or 16 gauge material.

The RPM is equipped with plastic non-marking adjustable feet that have a ±1/8" range of adjustment to allow for a precise and level system in almost any uneven surface environment.

The mirror(s) shall be 94% reflective optical quality first surface glass, protected with a rubber compression gasket utilizing 3-point suspension to ensure mirror surface flatness.

Features:

- Screen and a screen frame of choice.
- Designed to the specific projector and screen criteria, and to the physical characteristics of the utilized space.
- Fine-Tuning Projector Cradle (a 6-Axis adjustment projector mount) standard on all units.
- Mirror(s) positively pre-located in the manufacturing process and therefore preset in a fixed position.
- Fine-Tuning Projector Cradle mounting plate design to accept the specified projector.
- Available as a one (single-fold) or two (double fold) mirror system.
- Standard with first surface projection grade mirror(s) up to 48" x 60".
- Frame constructed of heavy-duty aluminum extrusion with black anodized finish and a connector block of die cast zinc alloy with a black powder coat finish.
- Easily assembled utilizing unique 8mm T-bolts and serrated washer nuts.
- Perfect Image Mirror Management System to allow for precise image adjustment (for 36" x 50" and 42" x 60" mirrors).



Options:

- Heavy-Duty adjustable "fine tuning" cradle is available for projectors in excess of 50 pounds.
- Slide Projector Shelf.



- Choose from Polacoat® Da-Plex, Da-Glas, Da-View or Data Pro rear projection screens with a factory frame.



- Fine tuning cradle offers a host of alignment adjustments for off axis and on axis projectors.



- Frame constructed of square aluminum extrusion for durability and precision.



- True flat trapezoid shaped mirror features a three-point suspension system, which ensures superior stability and flatness.



- The Perfect Image mirror adjustment system allows for precise image adjustment to correct barrel distortion and pin cushioning.

REAR PROJECTION MODULE (RPM)

Rear Projection Module (RPM) Suggested Specifications:

The Rear Projection Module (RPM) is a precision, aluminum extrusion based rear projection module. It is designed specifically to meet the exacting requirements of newer, digital projectors, and is manufactured to precise tolerances. The RPM is used to save valuable real estate by folding the projector's light path utilizing an optical quality first surface glass mirror. State-of-the-Art solid modeling software is used to design the RPM.

The RPM shall be constructed of matte black anodized 1 3/4" square aluminum extrusion. The aluminum shall be 6063-T6 Alloy with a 1/8" typical wall. The connections of the extrusion shall be die cast Zinc #3 alloy powder-coated corner blocks. All sheet metal parts shall be powder-coated steel utilizing a minimum of 14 or 16 gauge material.

The RPM is equipped with plastic non-marking adjustable feet that have a $\pm 7/8$ " range of adjustment to allow for a precise and level system in almost any uneven surface environment.

The standard mirror(s) shall be 94% reflective optical quality first surface glass, protected with a rubber compression gasket, utilizing 3-point suspension to ensure mirror surface flatness.

Features:

- Designed to the specific projector and screen criteria, and to the physical characteristics of the utilized space.
- Fine-Tuning Projector Cradle (a 6-Axis adjustment projector mount) standard on all units.
- Mirror(s) positively pre-located in the manufacturing process and therefore preset in a fixed position.
- Fine-Tuning Projector Cradle mounting plate design to accept the specified projector.
- Available as a one (single-fold) or two (double fold) mirror system.
- Standard with first surface projection grade mirror(s) up to 48" x 60".
- Frame constructed of heavy-duty aluminum extrusion with black anodized finish and a connector block of die cast zinc alloy with a black powder coat finish.
- Easily assembled utilizing unique 8mm T-bolts and serrated washer nuts.
- Perfect Image Mirror Management System to allow for precise image adjustment (for 36" x 50" and 42" x 60" mirrors).

Options:

- Mylar® mirror(s) with "fine tuning" adjustment points. The Mylar® mirrors are 86% reflective and lightweight.
- Heavy-Duty adjustable "fine tuning" cradle is available for projectors in excess of 50 pounds.
- Slide Projector Shelf.

General Specifications For Glass Front Surface Projection Mirrors:

- First surface glass mirrors optical quality, 94% reflective, and used in the RPM and TTW systems.
- Oversize mirrors backed with stiffeners are bonded to the surface to maintain flatness.

Reflectance:	94%
Adhesion:	No mirror surface will be lifted by the "cellophane tape adhesion test"
Temperature Stability:	-30°C to 260°C
Flatness:	Maximum 2 fringes per inch
Size:	Up to 48" x 60". Other custom sizes available upon request.
Size Tolerance:	$\pm 1/4$ "



- Fine tuning projector cradle standard with a host of alignment adjustments.



- Module constructed with Heavy Duty 1 3/4" square aluminum extrusion tubing for durability and precision.



- Adjustable feet compensate for uneven floors.

General Specifications For Mylar® Front Surface Projection Mirrors:

- Mylar® mirrors have a high optical quality, 86% reflective, and can be used in place of the first surface glass mirrors.

Reflectance:	86%
Temperature Stability:	-20°C to 50°C -4°F to 122°F
Size:	Up to 56' x 84" HxW.
Size Tolerance:	$\pm 1/4$ "
Washable:	Can only be cleaned with compressed air.

STAND ALONE

Stand Alone Suggested Specifications:

The Stand Alone System is an extension of the Thru-the-Wall System that marries a rear projection screen and frame to the Rear Projection Module structure in one complete package. Easy to assemble, the Stand Alone allows for a large image to be displayed in existing rooms and become a permanent or semi-permanent part of the facility. Custom engineered to accommodate a wide range of LCD and DLP projectors; the Stand Alone is an ideal alternative to an in-wall screen or a bulky data monitor.

Features:

- Stand Alone Enclosures are designed to the specific projector and screen that is used.
- Access from front or rear.
- Standard with a fully adjustable "fine-tuning" cradle that is designed to accept the specified projector that allows for precise image registration.
- Cradles are constructed of powder-coated heavy-duty steel and utilize color-coded knobs for easy adjustment.
- Perfect Image Mirror Management System to allow for precise image adjustment (for 36" x 50" and 42" x 60" mirrors).

Options:

- Black or light oak laminate cladding.
- Gray or black carpet cladding.
- Three-inch diameter solid urethane caster kit.
- Cooling fans with power cord.



- Optional with laminate or carpet cladding.



- Optional cooling fans increase air circulation.



- Frame constructed of square aluminum extrusion for durability and precision.



- Projector cradle is custom engineered to each projector.



General Specifications For Glass Front Surface Projection Mirrors:

- First surface glass mirrors optical quality, 94% reflective, and used in the RPM and TTW systems.
- Framed using 1 3/4" black anodized aluminum extrusion to insure stability and flatness.
- Oversize mirrors backed with stiffeners are bonded to the surface to maintain flatness.

Reflectance:	94%
Adhesion:	No mirror surface will be lifted by the "cellophane tape adhesion test"
Temperature Stability:	-30°C to 260°C
Flatness:	Maximum 2 fringes per inch
Size:	Up to 48" x 60". Other custom sizes available upon request.
Size Tolerance:	±1/4"

DA-LITE SCREEN COMPANY, INC.
3100 North Detroit Street
P. O. Box 137
Warsaw, IN 46581-0137 U.S.A.
Phone: 574-267-8101
800-622-3737
Fax: 574-267-7804
www.da-lite.com
info@da-lite.com

© Copyright 2008. Printed in U.S.A.