



DESIGNER ELECTROL®

Automatic Electric Projection Screen Model

SPECIFICATION DATA

DA-LITE SCREEN COMPANY, INC.
3100 North Detroit Street
Post Office Box 137
Warsaw, Indiana 46581-0137
Phone: 574-267-8101
800-622-3737
Fax: 574-267-7804
Toll Free Fax: 877-325-4832
www.da-lite.com
e-mail: info@da-lite.com

SUGGESTED SPECIFICATIONS: _____ projection screen(s), _____ (H) x _____ (W), electrically operated 120 V (60 Hz) not more than 2.4 amp. Shall have specifically designed motor mounted inside the roller, to be three wire with ground quick reversal type, oiled for life, with automatic thermal overload cut-out, integral gears, capacitor and an electric brake to prevent coasting. To have pre-set but adjustable limit switches to automatically stop picture surface in the "up" and "down" positions. The roller to be rigid metal. Screen fabric to be seamless, flame retardant and mildew resistant fiberglass with black masking borders standard. Bottom of fabric shall be formed into a pocket holding a metal rod. Case to be wood finished in either veneer or laminate on all facing sides and painted on non-facing sides. The front of the case is easily removed for installation and access to motor limit switches and fabric. Sturdy mounting brackets installed for wall or ceiling installation. To be complete with three position control switch with cover plate. Screen to be listed by Underwriters' Laboratories.

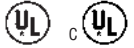

Matte White: Seamless in all standard sizes.

High Power®: Horizontal seam required when both dimensions exceed 6'.

VIDEO (NTSC 4:3) FORMAT DIMENSIONS (2" standard black drop at top)

Viewing Area		Nominal Diagonal		A - Overall Length of Case		B - Between Hanger Eyes		Approx. Ship. Wt.	
H x W	Cm	In.	Cm	In.	Cm	In.	Cm	Lbs.	Kg
50" x 67"	127 x 170	84"	213	81"	206	70"	178	56	25.4
60" x 80"	152 x 203	100"	254	95"	241	84"	213	67	30.4
69" x 92"	175 x 234	120"	305	107"	272	96"	244	77	34.9

SQUARE FORMAT DIMENSIONS

Sizes		A - Overall Length of Case		B - Between Hanger Eyes		Approx. Ship. Wt.	
H x W	Cm	In.	Cm	In.	Cm	Lbs.	Kg
70" x 70"	178 x 178	81"	206	70"	178	60	27.2
84" x 84"	213 x 213	95"	241	84"	213	70	31.8
96" x 96"	244 x 244	107"	272	96"	244	80	36.3

Specifications subject to change without notice.

Overall case length dimensions ±1/4".

Custom formats and sizes available upon request.

WHEN ORDERING, MARK APPROPRIATE SELECTIONS:

Select size from charts above.

Select viewing surface:

Matte White

High Power®

Greenguard® and Greenguard® Children and Schools Certified.

CASE STYLE:

- Concord
- Lexington
- Cambridge
- Hamilton
- Lancaster
- Yorkshire

FINISH:

- Laminate:**
- (Cambridge Only)
 - Figured Mahogany
 - Light Oak
 - Gunstock Walnut
 - Cherry
 - Custom

Veneer:

- Light Oak
- Medium Oak
- Natural Walnut
- Heritage Walnut
- Mahogany
- Cherry
- Honey Maple
- Custom

Optional Accessories:

- Single motor Low Voltage Control (LVC) - external.
- Wireless Remote Control for LVC.
 - Radio Frequency Remote Control.
 - Radio Frequency Range Extender available
 - Infrared Remote Control.
- Silent Motor.
- Key Locking Cover Plate for 120 V or LVC.
- Key Operated Switch for 120 V only (Cannot be used with LVC).
- No borders (Black masking borders standard).
- 220 Volt (50 Hz) motor.
- Video Projector Interface Control - external.
- External SCB-100 - RS-232 Serial Control Board
 - NET-100 Ethernet-Serial Adapter

Project:	_____
Architect:	_____
Phone:	_____
Contractor:	_____
Phone:	_____
Supervisor:	_____
Phone:	_____
Date:	_____
Revised:	_____

DESIGNER ELECTROL®

OVERALL LENGTH A = FABRIC WIDTH + 11" (28 Cm)
LENGTH B IS DISTANCE BETWEEN MOUNTING
HOLES ON BRACKETS AND IS THE FABRIC WIDTH.

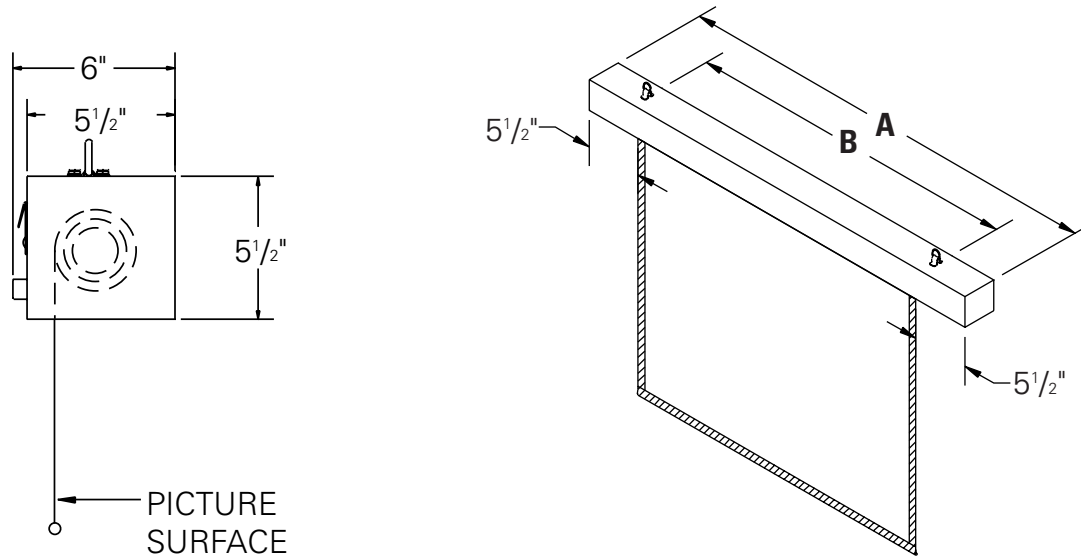

METHODS OF INSTALLATION

WALL MOUNTING

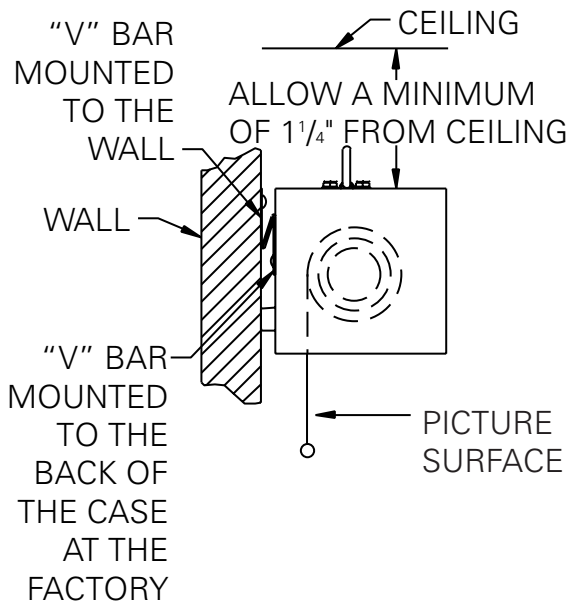

CEILING MOUNTING

