



32 31 00/AMS  
BuyLine 8638

# FIXED LOUVER FENCING



**Stainless  
Steel  
or  
Aluminum  
with  
Polyester  
Powder Coating**

Visit our Web Site [www.ametco.com](http://www.ametco.com)  
for Master Spec • CAD Drawings • Photo Gallery



# FIXED LOUVER FENCING

## VENETIAN®

### *Venetian® Aluminum*



#### Characteristics

The fixed louver Venetian Design allows 100% visual screening in any direction and still allows airflow for ventilation.

#### Applications:

Because Venetian Design allows 100% visual screening in any direction, screening of equipment, trash enclosures, parking garages, etc. can be achieved by running the louver either vertically or horizontally.

#### Specify:

Tig welded extruded aluminum Venetian Design has V-shaped extruded aluminum main bars on 2.625" centers with extruded aluminum framing bars. The extrusions are type 6063. The aluminum extrusions are polyester powder coated after fabrication. The Venetian Aluminum design weight is 3.5 lbs. per square foot.

Panel Width

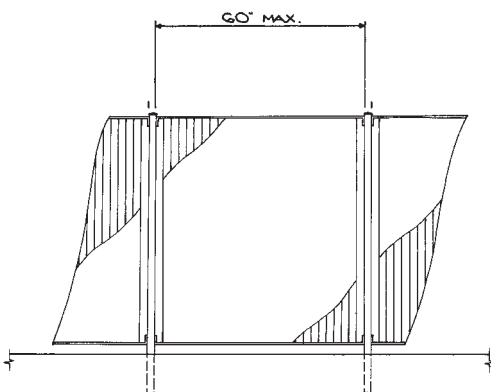

End View

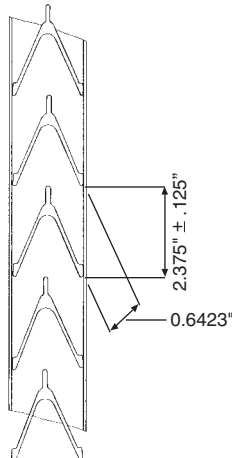

Aluminum Extrusion

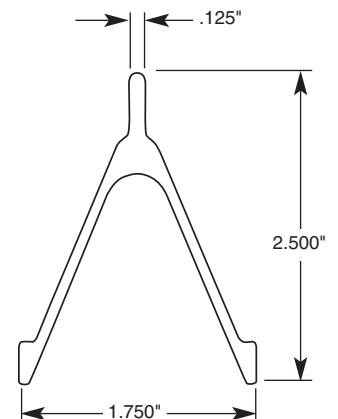

# ECLIPSE®

## Eclipse® Aluminum

## Eclipse® Stainless

### Characteristics

The fixed louver family of Eclipse Design allows 80% and 100% direct visual screening.

### Specify:

Extruded Aluminum or Stainless Steel Eclipse design has formed or extruded inclined main bars. Cross bars are on centers up to 18". Eclipse Aluminum is 6063 extrusions. Eclipse Stainless is type 304 stainless. Both are polyester powder coated. The Eclipse Aluminum design weight is 1.3 lbs. per square foot. The Eclipse Stainless Steel is 2.8 lbs. per square foot.



## 80% Direct Visual Screening

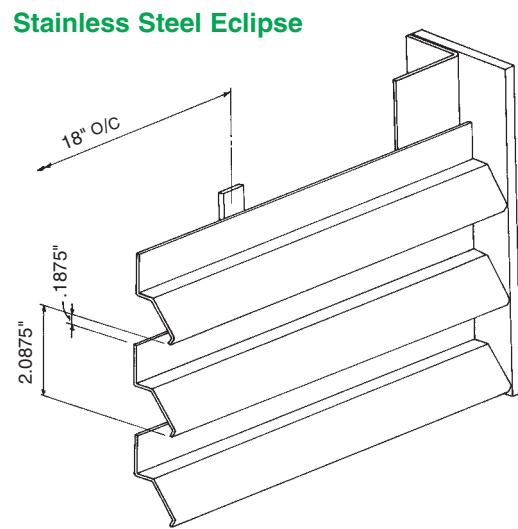
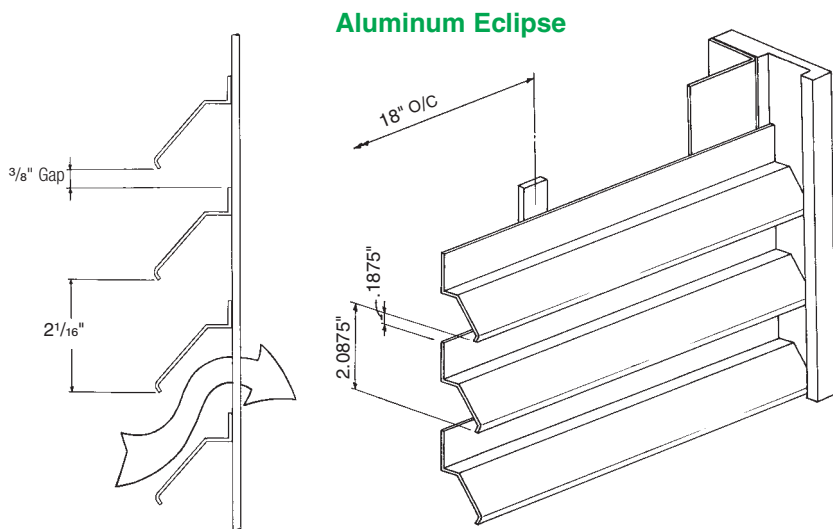

## 100% Direct Visual Screening

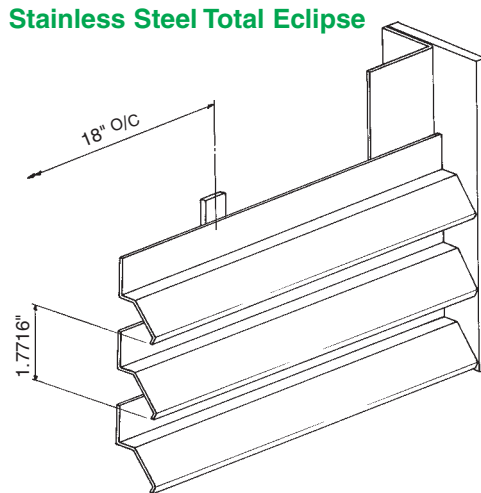
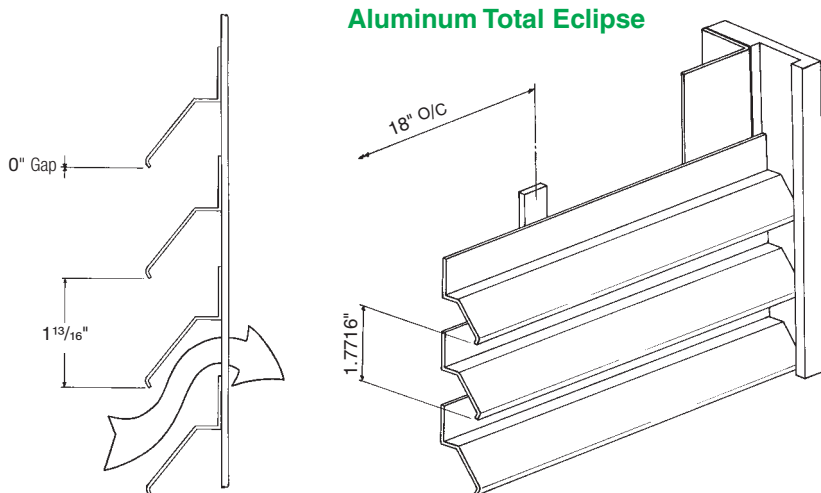



# PHOENIX<sup>®</sup>

## Phoenix<sup>®</sup> Aluminum

**Characteristics**

The Phoenix Design allows 80% or 100% direct visual screening.

**Specify:**

The Phoenix Design is the strongest of Ametco's fixed louver fencing and gates. Manufactured from 6063 extruded aluminum louvers, the Phoenix Design can have post centers of 8 foot and still maintain its outstanding strength.

The powder coated aluminum extrusions are maintenance free. The choice of color allows the Phoenix Design fencing and gates to fit perfectly into modern architectural and security applications. The Phoenix Aluminum design weight is 4 lbs. per square foot.

**AMETCO PHOENIX DESIGN  
USED HORIZONTALLY AS PICTURED**

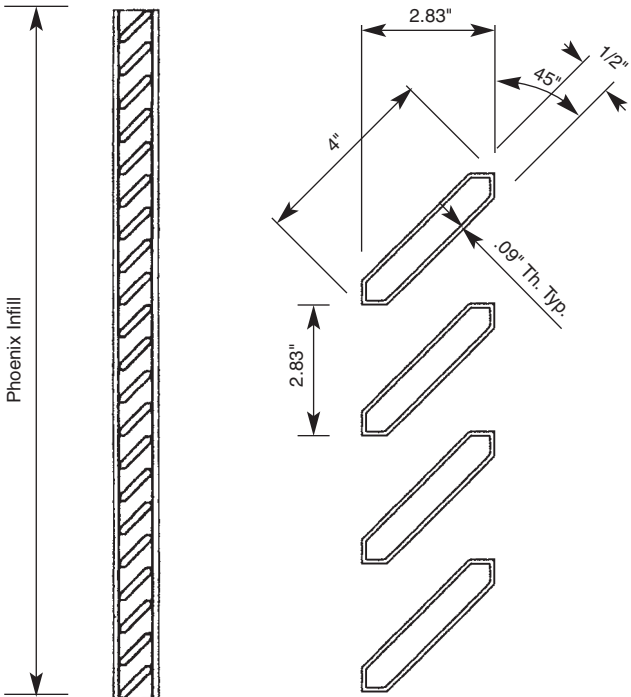
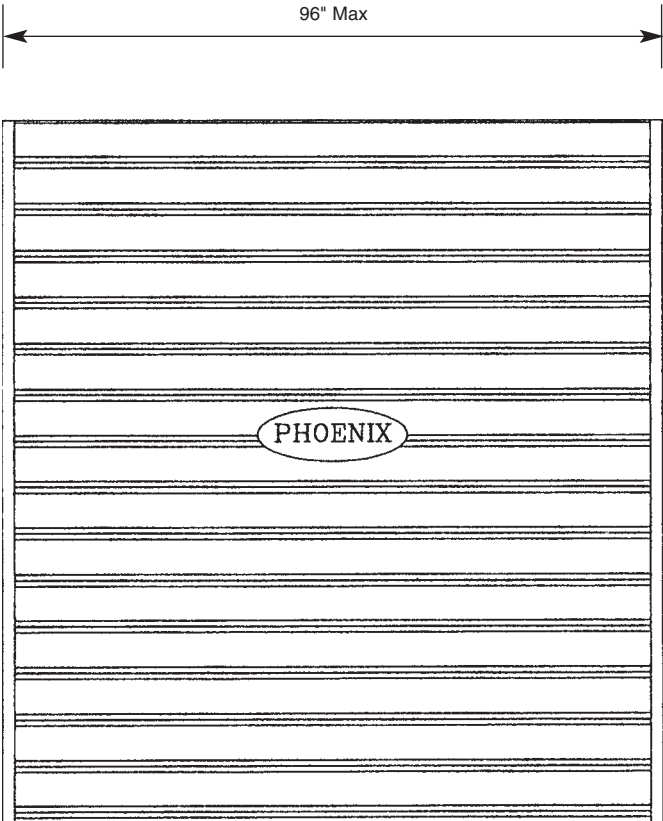

Patent No. US D535,760 S

**Visit our Web Site [www.ametco.com](http://www.ametco.com)  
for Master Spec • CAD Drawings • Photo Gallery**



4326 Hamann Parkway  
P.O. Box 1210  
Willoughby, Ohio 44096  
Web Site [www.ametco.com](http://www.ametco.com)

Phone (440) 951-4300  
Fax (440) 951-2542  
Toll Free 800-362-1360  
E-Mail [ametco@ametco.com](mailto:ametco@ametco.com)