

Wabo® SeismicCover Interior

Interior Seismic Expansion Control Cover System

Features	Benefits
<ul style="list-style-type: none"> • Durable and Time Tested 	<p>Designed to withstand multi-directional movement. Excellent, low maintenance system.</p>
<ul style="list-style-type: none"> • Exceeds Industry Standards 	<p>Heavy-duty components yields increased performance capability.</p>
<ul style="list-style-type: none"> • Variable Plate Width 	<p>Accommodates wide joint openings.</p>
<ul style="list-style-type: none"> • Surface Mounted Plate 	<p>Conceals irregularities in joint opening and protects wall finishes.</p>

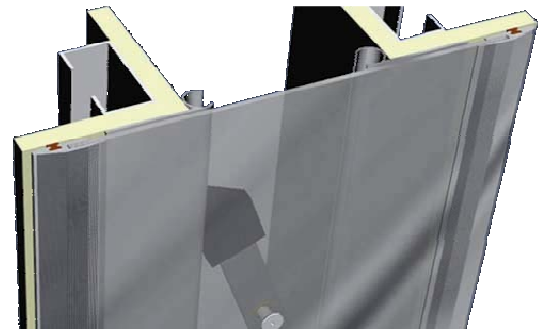

DESCRIPTION:

Wabo® SeismicCover WFI/WFT accommodates multi-directional movement while offering flexible design options for a variety of site conditions. The system provides a simple, attractive and durable solution for areas exposed to the general public and possible vandalism. Metal covers are available in aluminum, bronze, brass or stainless steel.

Wabo® ColorChoice anodized aluminum provides a cost-effective aesthetic colorable option when wide seismic conditions exist.

RECOMMENDED FOR:

- All interior wall, ceiling, and soffit expansion joint applications.
- For use in various construction projects including:
 - Health-Care
 - Transportation
 - Recreation
 - Retail
 - Commercial
 - Educational

PACKAGING/COVERAGE:

- Aluminum Profiles: bundled and palletized in standard 10-foot lengths
- Accessories: All other materials packaged in manufacturer's standard labeled carton.

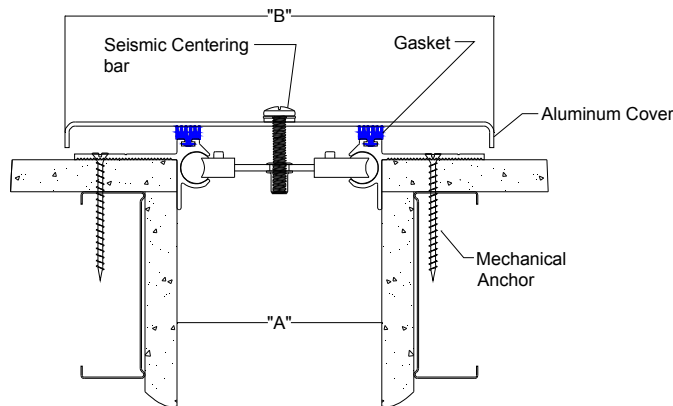

Note: see product sales drawings for additional details

Model WFI

MODEL NUMBER	JT. OPENING "A"		SYSTEM WIDTH "B"		TOTAL MOVEMENT	
	inches	mm	inches	mm	inches	mm
WFI-200	2.0	51	6.38	162	3.00	76
WFI-400	4.0	102	8.38	213	6.00	152
WFI-600	6.0	152	11.38	289	9.00	229
WFI-800	8.0	203	14.38	365	12.00	305
WFI-1000	10.0	254	17.00	432	15.00	381
WFI-1200	12.0	305	19.75	502	18.00	457
WFI-1800	18.0	457	28.75	730	27.00	686
WFI-2400	24.0	610	37.75	959	36.00	914
WFI-200C	2.0	51	3.75	95	3.00	76
WFI-400C	4.0	102	6.75	171	6.00	152
WFI-600C	6.0	152	9.75	248	9.00	229
WFI-800C	8.0	203	12.75	324	12.00	305
WFI-1000C	10.0	254	15.88	403	9.75	248
WFI-1200C	12.0	305	18.88	479	11.75	299
WFI-1800C	18.0	457	27.88	708	17.75	451
WFI-2400C	24.0	610	36.88	937	23.75	603

PHYSICAL PROPERTIES

Aluminum Base Extrusion:

ASTM B221, alloy 6063-T6 or 6061-T6

Aluminum Slide Plate:

Provide minimum 1/8" thick plate with material conforming to ASTM B209, alloy 5005-H34 "Guaranteed Anodized Quality". Extruded edge profile shall be material conforming to ASTM B221, alloy 6063-T5.

Self-Centering Bar:

Manufactured incorporating corrosion resistant nylon components with spherical ends.

Leaf Spring Attachment (corner condition):

Material shall conform to A.I.S.I. 301 Stainless Steel.

Gasket:

Provide extruded profile designed to protect wall surface. Material shall be polyvinyl chloride.

Finish:

Exposed aluminum surfaces standard-clear anodized, Class II AA-M10 C22 A31 (0.4-0.7 thick anodic coating)



APPLICATION:

Installation Summary:

- Protect all expansion joint components from damage during installation and protect finished installation from damage from other trades during all work activities.
- Expansion joint systems shall be installed in accordance with manufacturer's typical details and installation procedures.
- Wall or ceiling construction and materials shall be designed to allow for proper installation of system and its components. Construct any wall recess in accordance with manufacturer's recommendations.
- Construct joint openings consistent in width and straight along joint height. Utilize double metal studs on both sides of the joint opening. Inspect and verify all substrates to be solid and sound prior to work.
- Construct all adjacent walls to be vertically flat along height and flush across both sides of the opening. Inspect and verify all substrates to be solid and sound prior to work.
- Install required gypsum wallboard inside joint opening at fire rated locations. Install appropriate fire barrier system, if required by building code and rated construction. Contact WBA for recommendations on appropriate fire barrier system.
- Metal components shall be cut to length on job site where required. Components shall be miter cut in the field to conform to directional changes unless otherwise contracted with expansion joint manufacturer.
- All anchor holes shall be field drilled in accordance with manufacture's drawings.

For Best Results:

- Do not install if the joint's anticipated movement will exceed the system's movement range.
- Deliver product in each manufacturer's original, intact, labeled containers. Protect the work area with appropriate plastic sheeting.
- Do not allow any of the components to freeze prior to installation. Store all components out of direct sunlight in a clean, dry location between 50°F (10°C) and 90°F (32°C). Store off the ground and protect from weather and construction activities.
- Do not use for external locations, which require watertight expansion joint system. Contact WBA for recommendations.
- Periodically inspect the installed material and repair localized areas as needed. Inspect for loose components and/or hardware, repair as necessary. Consult a Watson Bowman Acme representative for additional information.
- Make certain the most current version of the product data sheet is being used. Please consult the website (www.wbacorp.com) or contact a customer service representative.
- Proper application is the responsibility of the user. Field visits by Watson Bowman Acme personnel are for the purpose of making technical recommendations only and not for supervising or providing quality control on the jobsite.

Related Documents:

- Material Safety Data Sheets
- Wabo®SeismicCover Specification
- Wabo®SeismicCover Sales Drawings
- Wabo®SeismicCover Installation Procedure

LIMITED WARRANTY:

Watson Bowman Acme Corp. warrants that this product conforms to its current applicable specifications. WATSON BOWMAN ACME CORP. MAKES NO OTHER WARRANTY, EXPRESS OR IMPLIED, INCLUDING ANY WARRANTY OF MERCHANTABILITY OR WARRANTY OF FITNESS FOR A PARTICULAR PURPOSE. The sole and exclusive remedy of Purchaser for any claim concerning this product, including, but not limited to, claims alleging breach of warranty, negligence, strict liability or otherwise, is the replacement of product or refund of the purchase price, at the sole option of Watson Bowman Acme Corp. Any claims concerning this product shall be submitted in writing within one year of the delivery date of this product to Purchaser and any claims not presented within that period are waived by Purchaser. IN NO EVENT SHALL WATSON BOWMAN ACME CORP. BE LIABLE FOR ANY SPECIAL, INCIDENTAL, CONSEQUENTIAL (INCLUDES LOSS OF PROFITS) OR PUNITIVE DAMAGES. Other warranties may be available when the product is installed by a factory trained installer. Contact your local Watson Bowman Acme representative for details. The data expressed herein is true and accurate to the best of our knowledge at the time published; it is, however, subject to change without notice.

Contact

Watson Bowman Acme Corp. 95 Pineview Drive, Amherst, NY 14228
phone: 716-691-7566 / fax: 716-691-9239 / web site: <http://www.wbacorp.com>

WaboSeismicCoverint_608