

Wabo®TwinSeam

Interior Floor Expansion Control System

Features	Benefits
<ul style="list-style-type: none"> • Surface Mount 	Reduces construction costs, no preformed blockouts required.
<ul style="list-style-type: none"> • Low Height 	Accommodates a variety of floor surfaces.
<ul style="list-style-type: none"> • Designed per ADA guidelines 	Pedestrian friendly
<ul style="list-style-type: none"> • Colorable Flat Seal 	Attractive flush design



DESCRIPTION:

Wabo®TwinSeam is a durable interior floor and wall expansion control system capable of accommodating multidirectional thermal and seismic movement. The attractive system provides a totally flush finish that is easily installed and surface mounted directly to the concrete floor slab. Traditional preformed blockouts are not typically required. Designed for reliable high volume service Wabo®TwinSeam's heavy-duty elastomeric seal makes the system ideal for small-wheeled carts and sensitive equipment. The system is so versatile that it easily accommodates typical 5/8-inch gypsum wallboard construction with a totally flush installation. All models comply with ADA guidelines and accommodates finish material inlays up to 1/4 – inch thickness.

RECOMMENDED FOR:

- All Interior floor expansion joint applications.
- For use in various construction projects including:
 - Health-Care
 - Transportation
 - Recreation
 - Retail
 - Commercial
 - Educational

PACKAGING/COVERAGE:

- Expansion joint aluminum components are shipped in standard 10 foot lengths.
- Elastomeric seal is boxed and shipped in continuous lengths.
- All materials and components are palletized and/or packaged in manufacturer's standard labeled carton.
- Aluminum profiles supplied in standard mill finish.

TECHNICAL DATA:

Design Information:

Wabo®TwinSeam is simple to install for easy assembly. The low height system requires no blockouts to be formed, reducing construction costs. Offered as a floor-to-floor or floor-to-wall system, Wabo®TwinSeam can be used in joint openings up to 6-inches and accommodates various project conditions.

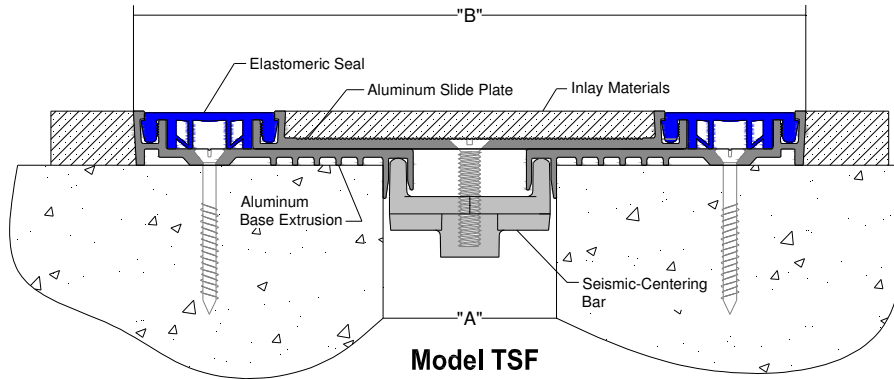

Note: see product sales drawings for additional details

Movement Table

MODEL NUMBER	JOINT OPENING ("A")		SYSTEM WIDTH ("B")		TOTAL MOVEMENT	
	inches	mm	inches	mm	inches	mm
TSF-200	2.0	51	7.75	197	4.25	108
TSF-400	4.0	102	9.75	248	6.25	159
TSF-600	6.0	152	11.75	298	8.25	210
TSF-200C	2.0	51	4.875	124	2.50	64
TSF-400C	4.0	102	6.875	175	4.50	114
TSF-600C	6.0	152	8.875	225	6.50	165

PHYSICAL PROPERTIES:

Aluminum Extrusions and Shapes: Materials shall conform to properties of ASTM B221, 6063-T6 or ASTM B209, 5005-H34 aluminum alloy.

Elastomeric Seal: Material shall be flexible extruded polyvinyl chloride or manufacturer's alternate material exhibiting a minimum shore A hardness of 60 +/- 5 with UV stabilizer. Standard Color: Black.

Seismic Centering Bar: Provide corrosion resistant molded nylon bar with integral threaded brass insert for slide plate assembly.

Moisture Barrier (optional): Provide fabric reinforced clear vinyl



APPLICATION:

Installation Summary:

- Protect all expansion joint components from damage during installation and protect finished installation from damage from other trades during all work activities.
- Expansion joint systems shall be installed in accordance with manufacturer's typical details and installation procedures.
- Floor construction and materials shall be designed to allow for proper installation of system and its components. Construct all blockouts (if applicable) in accordance with manufacturer's recommendations.
- Construct joint openings consistent in width and straight along joint length. Inspect and verify all substrates to be solid and sound prior to work. Remove any loose materials and repair any voids, and/or spalls with appropriate repair material.
- Construct all adjacent floors to be horizontally flat along length and flush across both sides of the opening. Inspect and verify all substrates to be solid and sound prior to work.
- Install appropriate fire barrier system, if required by building code and rated construction. Contact WBA for recommendations on appropriate fire barrier system.
- Metal components shall be cut to length on job site where required. Components shall be miter cut in the field to conform to directional changes unless otherwise contracted with expansion joint manufacturer.
- All anchor holes shall be field drilled in accordance with manufacture's drawings.

For Best Results:

- Do not install if the joint's anticipated movement will exceed the system's movement range.
- Deliver product in each manufacturer's original, intact, labeled containers. Protect the work area with appropriate plastic sheeting.
- Do not allow any of the components to freeze prior to installation. Store all components out of direct sunlight in a clean, dry location between 50°F (10°C) and 90°F (32°C). Store off the ground and protect from weather and construction activities.
- Do not use for external locations, which require watertight expansion joint system. Contact WBA for recommendations.
- Periodically inspect the installed material and repair localized areas as needed. Inspect for loose components and/or hardware, repair as necessary. Consult a Watson Bowman Acme representative for additional information.
- Make certain the most current version of the product data sheet is being used. Please consult the website (www.wbacorp.com) or contact a customer service representative.
- Proper application is the responsibility of the user. Field visits by Watson Bowman Acme personnel are for the purpose of making technical recommendations only and not for supervising or providing quality control on the jobsite.

Related Documents:

- Material Safety Data Sheets
- Wabo®TwinSeam Specification
- Wabo®TwinSeam Sales Drawings
- Wabo®TwinSeam Installation Procedure



LIMITED WARRANTY:

Watson Bowman Acme Corp. warrants that this product conforms to its current applicable specifications. WATSON BOWMAN ACME CORP. MAKES NO OTHER WARRANTY, EXPRESS OR IMPLIED, INCLUDING ANY WARRANTY OF MERCHANTABILITY OR WARRANTY OF FITNESS FOR A PARTICULAR PURPOSE. The sole and exclusive remedy of Purchaser for any claim concerning this product, including, but not limited to, claims alleging breach of warranty, negligence, strict liability or otherwise, is the replacement of product or refund of the purchase price, at the sole option of Watson Bowman Acme Corp. Any claims concerning this product shall be submitted in writing within one year of the delivery date of this product to Purchaser and any claims not presented within that period are waived by Purchaser. IN NO EVENT SHALL WATSON BOWMAN ACME CORP. BE LIABLE FOR ANY SPECIAL, INCIDENTAL, CONSEQUENTIAL (INCLUDES LOSS OF PROFITS) OR PUNITIVE DAMAGES. Other warranties may be available when the product is installed by a factory trained installer. Contact your local Watson Bowman Acme representative for details. The data expressed herein is true and accurate to the best of our knowledge at the time published; it is, however, subject to change without notice.

Contact

*Watson Bowman Acme Corp. 95 Pineview Drive, Amherst, NY 14228
phone:716-691-7566 / fax: 716-691-9239 / web site: <http://www.wbacorp.com>*

WaboTwinSeam_1206