

Pilkington Planar™

THE WORLD'S LEADING STRUCTURAL GLASS SYSTEM

GLASS FIN WALLS
TENSION STRUCTURES & CABLE NETS
ROOFS, SKYLIGHTS & CANOPIES

THE PILKINGTON PLANAR™ SYSTEM	4
Manufacturer	
W&W GLASS, LLC	5
ADVANTAGES AND BENEFITS	6
TESTING AND COMPARISON	7
GLASS TYPES	8
FITTINGS	9
Pilkington Planar™ Integral	
Pilkington Planar™ Intrafix	
STEEL SUPPORT STRUCTURES	10
GLASS MULLION SYSTEMS	12
TENSION STRUCTURES	14
CANOPY SYSTEMS	16
ROOFS AND SKYLIGHTS	18
PLANAR NET	20
PILKINGTON PLANAR™ TRIPLE INSULATED GLASS	22
Canadian Museum of Nature	
DUAL SKIN FACADES:	
NEW YORK PRESBYTERIAN HOSPITAL	24
USC STEM CELL RESEARCH BUILDING	26
PROJECT CASE STUDIES:	
JUILLIARD SCHOOL/ALICE TULLY HALL	28
BANK OF AMERICA TOWER	30
SPORTS FACILITIES	32
ONE POST OFFICE SQUARE	33
AMC THEATRE	34
COLUMBIA CENTER	35
NOVARTIS	36
601 LEXINGTON AVENUE	37
BROOKLYN MUSEUM OF ART	38
THE ROSE CENTER FOR EARTH AND SPACE	39

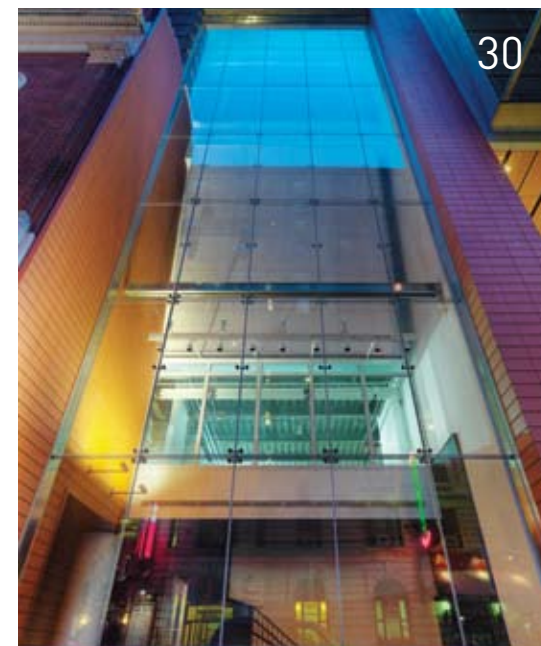

THE PILKINGTON PLANAR™ SYSTEM

UNRIVALED PERFORMANCE FOR OVER 45 YEARS—THERE IS NO EQUAL.

Pilkington Planar™ structural glass systems have a proven track record in the most demanding applications. Architects can have absolute confidence in our ability to create soaring facades, roofs, canopies, or even clad an entire building. Architects can be comforted that their clients will receive the most highly engineered system in the market backed by the most respected glass manufacturer in the world. Pilkington Planar™ readily adapts to the design team's requirements for designing backup structures that are simplistic or complex.

THE COMBINED EXPERIENCE OF ONE OF THE OLDEST AND LARGEST GLASS MAKERS IN THE WORLD ALONG WITH ONE OF THE LARGEST GLAZIERS IN THE UNITED STATES ASSURES A SAFE AND SUCCESSFUL RESULT!

MANUFACTURER

Pilkington has been one of the world's leading glass manufacturers for over 150 years. Pilkington provides the complete glazing system as a sole source to insure undivided responsibility. One of the world's largest glass research facilities supports a rigorous continual in-house testing program. This allows Pilkington to offer their 12 year comprehensive warranty that covers design, manufacturing, and installation.

Pilkington maintains a separate facility designed strictly for the manufacturing of the Pilkington Planar™ system. This results in exclusive glass features found only in the Planar System.



TOP: Blue Cross Blue Shield of MA,
Hingham, MA, Margulies Associates
BOTTOM: Interior elevator enclosure
Centre Square, Philadelphia, PA,
Daroff Design



PROJECT
Brooklyn Museum of Art

LOCATION
Brooklyn, NY

ARCHITECT
Polshek Partnership

FAMILY OWNED AND OPERATED FOR 70 YEARS IN THE METAL AND GLASS INDUSTRY PROVIDING SUPERIOR SOLUTIONS TO YOUR MOST CHALLENGING PROJECTS.

W&W GLASS, LLC

W&W Glass is the NY metropolitan area's largest architectural glass and metal contractor, specializing in Curtainwalls, Storefronts, Entrances, Ornamental Metal, Skylights, and Pilkington Planar™ structural glass systems.

W&W IS EXPERIENCED WITH VARIOUS PROJECT DELIVERY METHODS INCLUDING THE DESIGN ASSIST/DESIGN BUILD PROCESS. WE WORK WITH ARCHITECTS AND CONTRACTORS ALL OVER NORTH AMERICA AND THE CARIBBEAN.

W&W is a family owned business with a 70-year history in the metal and glass industry. The company is one of the largest metal and glass companies in the New York metropolitan area and the largest supplier of structural glass systems to the glazing industry in the country. W&W maintains a full-time estimating and engineering department ready to provide an engineered solution to your building enclosure needs.



PROJECT
Bank of America
Trading Floor

LOCATION
Charlotte, NC

ARCHITECT
SOM

MAJOR ADVANTAGES

1. Sole Source Manufacturing & Engineering In-house, sole source, quality assured system totally manufactured and controlled by Pilkington. The system is never sold by mixing outside glass or hardware suppliers. Pilkington and W&W maintain a dedicated in-house engineering staff that reviews every detail of each system prior to manufacture.

2. Superior Tempering Minimum compressive strength of 16,000 psi in a custom built modern furnace versus typical domestic tempering of approximately 11,500 psi. This gives the glass added strength so that even when it is subjected to required high static and dynamic loading, there will be very high factors of safety at the hole locations where maximum stress occurs.

3. Research and Testing Pilkington maintains one of the largest glass research testing facilities in the world and regularly tests in-house for various Pilkington Planar™ projects.

4. 12-Year Warranty Gives You Absolute Confidence Continual and rigorous testing programs have given us a wealth of knowledge concerning structural glass systems. This has allowed us to introduce a Code of Practice for structural glass facades. Every part of every Pilkington Planar™ solution is designed in accordance with this criteria. This means we can give Pilkington Planar™ a 12 year design and materials warranty, and give you total confidence in the system's performance and reliability.

5. Rollerwave Distortion Control Rollerwave distortion (the visual waviness inherent in tempered glass) is reduced to an average of 0.0007" peak to valley for tempered glass in lieu of the published norm of 0.05". This exclusive feature significantly reduces visual rollerwave allowing the glass to accurately reflect its surroundings.



Pilkington Planar™ Glass



Other Fabricated Glass Products

ARCHITECTS, ENGINEERS AND CONSULTANTS ARE CONTINUALLY DEMANDING HIGHER PERFORMANCE AND CREATING NEWER AND MORE COMPLEX DESIGNS.

When you select the Pilkington Planar™ system, you are selecting the most tested system available in the marketplace. You are selecting a system backed by over 45 years of IN-HOUSE testing where the end product gives your client unparalleled levels of comfort in the knowledge that all systems are backed by the Pilkington 12 year total warranty.

RECENT TESTING

Testing never stops with the Pilkington Planar™ System. Recent testing has been carried out on Pilkington Planar™ Integral hidden bolt laminated glass, energy efficient Pilkington Planar™ Triple/insulated units, Pilkington Activ™ self-cleaning glass, and Pilkington Intrafix concealed bolt IG units.

Fail-Safe Redundancy of Fins A consultant demanded an unprecedented fail-safe, redundancy test that had never been done before. Under design load (40 psf), we remotely broke a glass fin to prove that the system would stay in place with a broken structural element on the wall. In addition, we tested for dynamic water, air, and seismic loading.



High Strength Laminated Fin Test

WHEN YOU SELECT THE PILKINGTON PLANAR™ SYSTEM, YOU ARE SELECTING THE MOST TESTED SYSTEM AVAILABLE IN THE MARKETPLACE.



Hurricane Testing With the development of the Planar™ | SentryGlas® Plus System, and with the growth of hurricane impact codes, Pilkington has successfully tested an impact resistant Planar™ facade for both large missile impact and cyclic loading in accordance with ASTM-E 1886.



Bomb-Blast Testing Pilkington leads the way with recent testing allowing Pilkington to design systems to the level 1 standard of the GSA when tested to both GSA level C and D standards.

GLASS PERFORMANCE FIGURES

INSULATED GLASS

10mm Outer Pane	16mm Cavity	6mm Inner Pane	Vtc	Rf(vis)	SHGCc	SCc	'U' Summer	'U' Winter
Pilkington Optifloat™ Center	Air	Pilkington K Glass™	0.71	0.16	0.64	0.74	0.32	0.33
Pilkington Optiwhite™	Air	Pilkington K Glass™ OW	0.77	0.17	0.77	0.89	0.32	0.33

10mm Outer Pane	16mm Cavity	6mm Inner Pane	Vtc	Rf(vis)	SHGCc	SCc	'U' Summer	'U' Winter
Pilkington Suncool™ 70/40 Pro T	Air	Pilkington Optifloat™ Clear	0.68	0.09	0.41	0.47	0.25	0.28

10mm Outer Pane	16mm Cavity	6mm Inner Pane	Vtc	Rf(vis)	SHGCc	SCc	'U' Summer	'U' Winter
Pilkington Optifloat™ Clear	Air	Pilkington Optitherm™ S3 Pro T	0.76	0.12	0.56	0.64	0.24	0.28

10mm Outer Pane	16mm Cavity	6mm Inner Pane	Vtc	Rf(vis)	SHGCc	SCc	'U' Summer	'U' Winter
Pilkington Planar Sun 73/42	Air	Pilkington Optifloat™ Clear	0.69	0.10	0.40	0.46	0.25	0.28
Pilkington Planar Sun 70/39	Air	Pilkington Optifloat™ Clear	0.67	0.11	0.37	0.43	0.24	0.27
Pilkington Planar Sun 69/37	Air	Pilkington Optifloat™ Clear	0.65	0.11	0.35	0.40	0.24	0.27
Pilkington Planar Sun 50/27	Air	Pilkington Optifloat™ Clear	0.47	0.10	0.26	0.30	0.25	0.27
Pilkington Planar Optifloat™ Clear	Air	Pilkington Optifloat™ SN	0.75	0.11	0.58	0.67	0.25	0.28

10mm Outer Pane	16mm Cavity	6mm Inner Pane	Vtc	Rf(vis)	SHGCc	SCc	'U' Summer	'U' Winter
Pilkington Optiwhite™ Planar Sun 73/42	Air	Pilkington Optiwhite™	0.74	0.11	0.43	0.49	0.24	0.28
Pilkington Optiwhite™ Planar Sun 70/39	Air	Pilkington Optiwhite™	0.72	0.12	0.40	0.46	0.23	0.27
Pilkington Optiwhite™ Planar Sun 69/37	Air	Pilkington Optiwhite™	0.70	0.12	0.38	0.44	0.23	0.27
Pilkington Optiwhite™ Planar Sun 50/27	Air	Pilkington Optiwhite™	0.51	0.10	0.28	0.32	0.25	0.27
Pilkington Optiwhite™	Air	Pilkington Optiwhite™ SN	0.81	0.12	0.67	0.77	0.24	0.28

LAMINATED GLASS

10mm Outer Pane	1.52mm Interlayer	6mm Inner Pane	Vtc	Rf(vis)	SHGCc	SCc	'U' Summer	'U' Winter
Pilkington Optifloat™ Clear	SentryGlas®	Pilkington K Glass™	0.76	0.09	0.59	0.68	0.64	0.57
Pilkington Optiwhite™	SentryGlas®	Pilkington K Glass™ OW	0.82	0.10	0.73	0.84	0.60	0.57

10mm Outer Pane	1.52mm Interlayer	6mm Inner Pane	Vtc	Rf(vis)	SHGCc	SCc	'U' Summer	'U' Winter
Pilkington Optifloat™ Clear	SentryGlas®	Pilkington Solar-E™	0.55	0.07	0.46	0.53	0.67	0.57

The figures listed above are indicative only. Some products have manufacturing limitations. Please visit our website or make a technical inquiry for specific product data.

PILKINGTON PLANAR™ FITTINGS



THE CONCEPT IS CLEAR: DESIGN, TEST, AND PLACE INTO SERVICE THE BEST ENGINEERED AND YET THE SMALLEST, MOST AESTHETICALLY PLEASING FITTING WITHOUT COMPROMISING PERFORMANCE.

Rigorous testing has led to the development of a standard set of fittings using 316 grade stainless steel. These fittings are designed to deal with extraordinary forces from seismic, snow and wind loads

Four and two point castings, as well as various 905 series fittings, represent only some of the many types of stainless steel connectors designed to connect the glass to the backup structure.

PILKINGTON PLANAR™ INTEGRAL

A fully tested and patented method of fixing laminated glass panels to a backup structure without any exterior bolts, caps or washers! All fittings are concealed within the laminated glass. This fixing system allows a much wider variety of glass types, including art and textured glass, to be used in a structural glass application. Integral allows us to horizontally glaze an entire roof or canopy without any fasteners in the exterior glass!

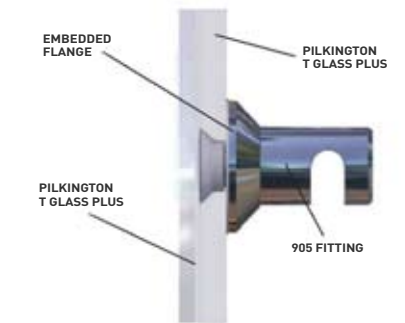

PILKINGTON PLANAR™ INTRAFIX

Intrafix can be specified for applications in which the design team wants an insulated wall without any external bolts, caps, or washers. This fixing mechanism captures the tempered or laminated inner leaf of an insulated unit with a stainless steel disk system which does not penetrate the outer glass. Planar Intrafix allows high performance coated glasses to be used for the external lite of the IG unit. Intrafix carries the Pilkington Planar™ 12 year warranty!

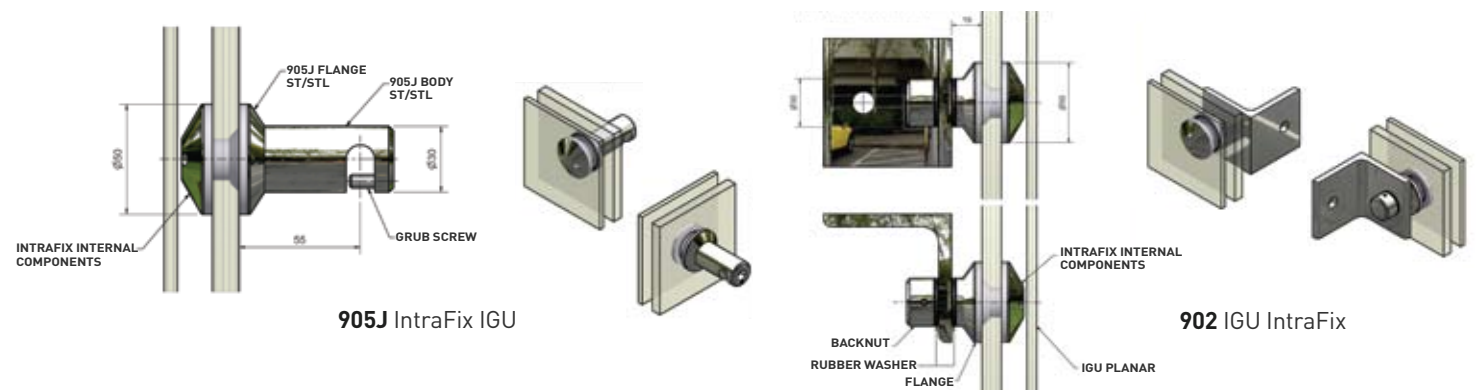

STEEL SUPPORT STRUCTURES

STEEL BACKUP STRUCTURES CAN BE ANYTHING FROM SIMPLE PIPE COLUMNS TO COMPLICATED, EXPRESSIVE TRUSS SYSTEMS.

W&W and Pilkington can design and supply, as a sole source system, both the glass and steel. In some instances when the design is very simple, it may be advantageous to allow the steel to be furnished and erected within the steel package, with coordination by Pilkington and W&W.

When the steel design becomes expressive, and close integration of the two products is needed, then we will supply both steel and glass as a single source.



PROJECT
601 Lexington Avenue

LOCATION
New York, NY

ARCHITECT
KlingStubbins



Harborside Financial Center, Plaza 5, Jersey City, NJ, Grad Associates



TOP: Las Vegas Motor Speedway, Las Vegas, NV, ai Design Group
BOTTOM: Metropolitan Transit Authority, Division 9 Transportation Building, Los Angeles, CA, Designer: MTA



PROJECT
Stevens Institute

LOCATION
Hoboken, NJ

ARCHITECT
Ecoplan

GLASS MULLION SYSTEMS

THE GLASS MULLION SYSTEM USES GLASS FINNS AS A MEANS OF SUPPORT FOR MAXIMUM TRANSPARENCY.

These glass facades must be suspended from the structure above with the glass panels fastened to the mullions by Pilkington Planar™ fittings. This means the combined weight of both the panels and the mullions is carried by the connection at the head of each fin. This allows you to design very high facades that do not exert large in-plane loads on the Pilkington Planar™ panels. All projects, in high seismic zones, must be suspended in this way.

Pilkington Planar™ has been thoroughly tested for use in areas of high seismic activity, which has been demonstrated by the system's excellent performance in previous seismic events in both California and Japan.



PROJECT
2000 Avenue of the Stars

LOCATION
Century City, CA

ARCHITECT
Gensler



Huntsville Airport, Huntsville, AL, Chapman Sisson Architects

A PILKINGTON PLANAR™ GLASS MULLION FACADE HAS BEEN DESIGNED AND TESTED TO WIND LOADS OF 270 PSF (320 MPH) FOR 15 MINUTES.



Genzyme Science Building, Framingham, MA, Architectural Resources Cambridge



225 Franklin Street, Boston, MA, CBT Architects

TENSION STRUCTURES

WE GUARANTEE THE DELIVERY, COMPATIBILITY, AND PERFORMANCE OF THE COMPLETE FACADE.

Various forms of cable-stayed backup system designs can be used to support a Pilkington Planar™ facade. They can take the form of simple strong back trusses, bow string trusses, or lighter weight, more filigree cable trusses. Designers have complete freedom and flexibility when designing these trusses.

In all instances, the capabilities and loading of the glass must be used as the basis of the design for the back-up structural system.

PROVEN PERFORMANCE

Pilkington Planar™ Tension Structures have already met high performance requirements for seismic loads, live and dead loads and wind loading including hurricane force winds.

These structures require early cooperation between the design team and W&W Glass to solve both design and budget questions. We offer full technical design services, starting from the basic concept, through 2D and 3D analysis, up to full design and performance specifications, mock-ups, and testing.



TOP: Harvard Medical School, Boston, MA, Architectural Resources Cambridge **CENTER: New York Presbyterian Hospital**, New York, NY, Pei Cobb Freed & Partners **BOTTOM: Santa Monica College Theater**, Santa Monica, CA, Renzo Zecchetto Architects



PROJECT
Santa Monica College
Theatre

LOCATION
Santa Monica, CA

ARCHITECT
Renzo Zecchetto Architects

CANOPY SYSTEMS

THE DESIGN FLEXIBILITY OF PILKINGTON PLANAR™ AND THE REDUCTION OF METAL FRAMING, WHICH CAN CAUSE MAINTENANCE PROBLEMS OVER TIME, MAKE PILKINGTON PLANAR™ THE PERFECT CHOICE FOR HORIZONTAL AND OVERHEAD GLAZING.

Pilkington Planar™ overhead glazing has undergone extensive seismic, impact, water and wind load testing. Backup structures can be supplied as a completely engineered sole source package for guaranteed performance of the complete skylight or canopy.

TECHNICAL CONSIDERATIONS

The backup structure is required to carry snow and other loads and resist negative wind pressures through the fitting locations. Large spans are possible if underlying purlins are reinforced with cable tension rod rigging. Pilkington Planar™ requires a minimum of 3 degrees of slope to eliminate ponding of water in the center of the glass.



PROJECT
Twelve Oaks Mall

LOCATION
Novi, MI

ARCHITECT
Neumann/Smith Architecture



Bowling Green Station, New York, NY, Dattner Architects



3rd Street Light Rail, San Francisco, CA
City of San Francisco Bureau of Architects



High Museum of Art, Atlanta, GA
Renzo Piano Building Workshop

ROOFS AND SKYLIGHTS

WHEN TRYING TO CREATE TRANSPARENT VIEWS OF ARTICULATED STRUCTURES, PILKINGTON PLANAR™ IS THE PERFECT WAY TO SIMPLIFY THE ALL GLASS SKYLIGHT. PILKINGTON PLANAR™ APPLICATIONS HAVE AN EXTENSIVE IN-SERVICE TRACK RECORD FOR SAFETY AND DURABILITY.

Horizontal applications are warranted for 12 years against delamination, leakage and seal failure (IG units). Early coordination with the building structure is needed, as well as consideration of snow and drift loads, seismic zone, drainage, etc. Steel can be engineered to use combinations of glass mullions and/or cable and steel structures.



TOP: Asia Society, New York, NY, Voorsanger & Associates
BOTTOM: Novartis Pharmaceuticals, East Hanover, NJ, Gensler



TOP: Park Tower Lobby, Costa Mesa, CA, Murphy Jahn Architects
BOTTOM: Pier 79 West Midtown Ferry Terminal, New York, NY, William Nicholas Bodouva + Associates

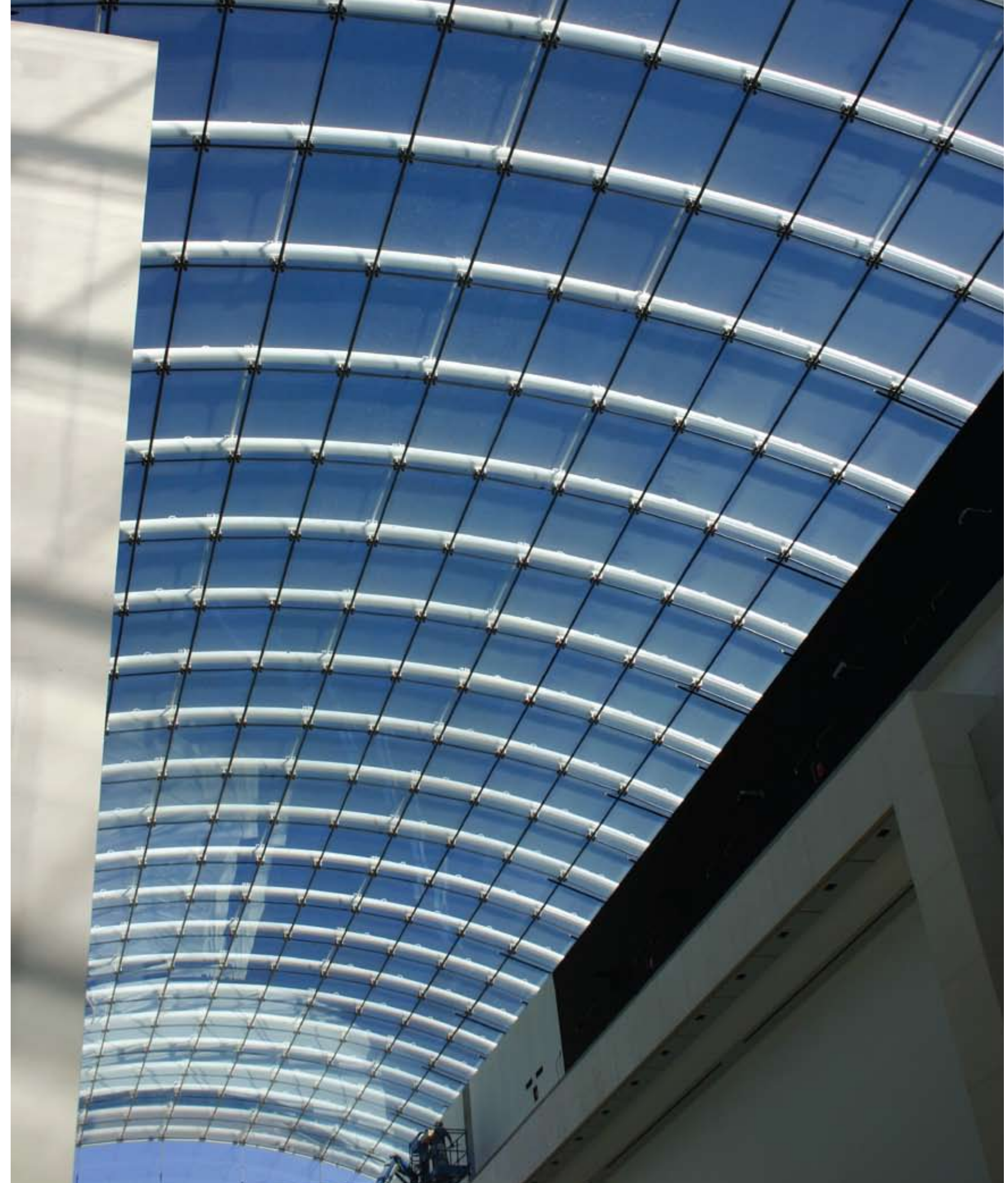

PROJECT
Yorkdale Mall

LOCATION
Toronto, Canada

ARCHITECT
MMC International

PLANAR NET

PILKINGTON AND W&W HAVE DEVELOPED AND TESTED THE PLANAR NET SYSTEM.

COMBINED WITH PLANAR INTEGRAL OR INTRAFIX DESIGNS, CABLE NETS CAN BE SUPPLIED WITHOUT ANY EXTERIOR FITTINGS OR PATCHES.

Planar Net uses the same principles used by the Pilkington Planar™ System by attaching Planar countersunk panels to pre-tensioned cables which are then attached to a coordinated boundary structure.



PROJECT
Alice Tully Hall
Juilliard School

LOCATION
New York, NY

ARCHITECT
Diller Scofidio & Renfro
with FXFowle



Time Warner Building, New York, NY, SOM



Planar Net fitting assembly



Bank of America Tower, New York, NY,
Cook+Fox Architects



Centre Square, Philadelphia, PA, Daroff Design Inc.

PILKINGTON PLANAR™ TRIPLE INSULATED GLASS

PILKINGTON INTRODUCES THE WORLD'S FIRST TRIPLE GLAZED FRAMELESS GLASS SYSTEM.

Triple glazing offers substantially lower U Values than traditional double glazed Pilkington Planar™. There are three layers of glass giving the architect multiple choices for increased solar performance and noise control. Performance figures available upon request.

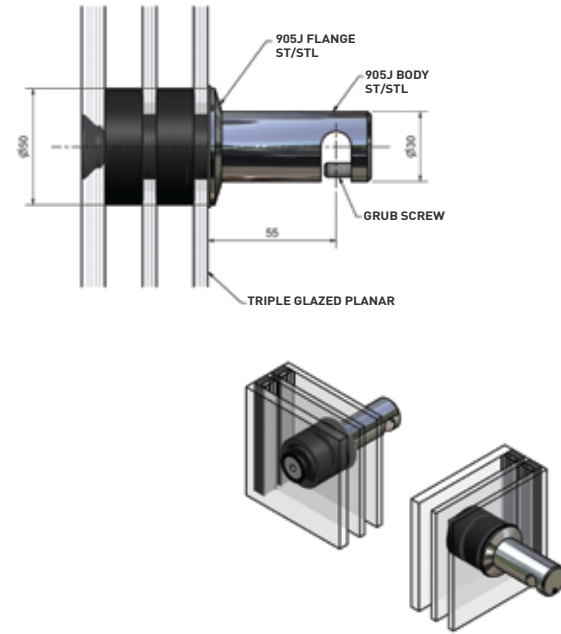

CANADIAN MUSEUM OF NATURE “THE QUEENS’ LANTERN”

THE LANTERN AT THE CANADIAN MUSEUM OF NATURE IS A 65’ HIGH TRIPLE GLAZED 3-SIDED GLASS CUBE PLANAR SYSTEM.

The glass type of the units are 12mm Optiwhite™ T-Plus, with a 6mm Optiwhite™ T-Plus middle lite, and the interior lite is 6mm energy advantage T-Plus. It was designed to handle the harsh Canadian winters common to the Ottawa area. The system is a combination of Pilkington Planar™ seismic 905 fittings on glass fins, which in this unique situation penetrate the face glass and protrude from the building. The corner units are attached to steel columns which are hung from the cantilevered roof structure.

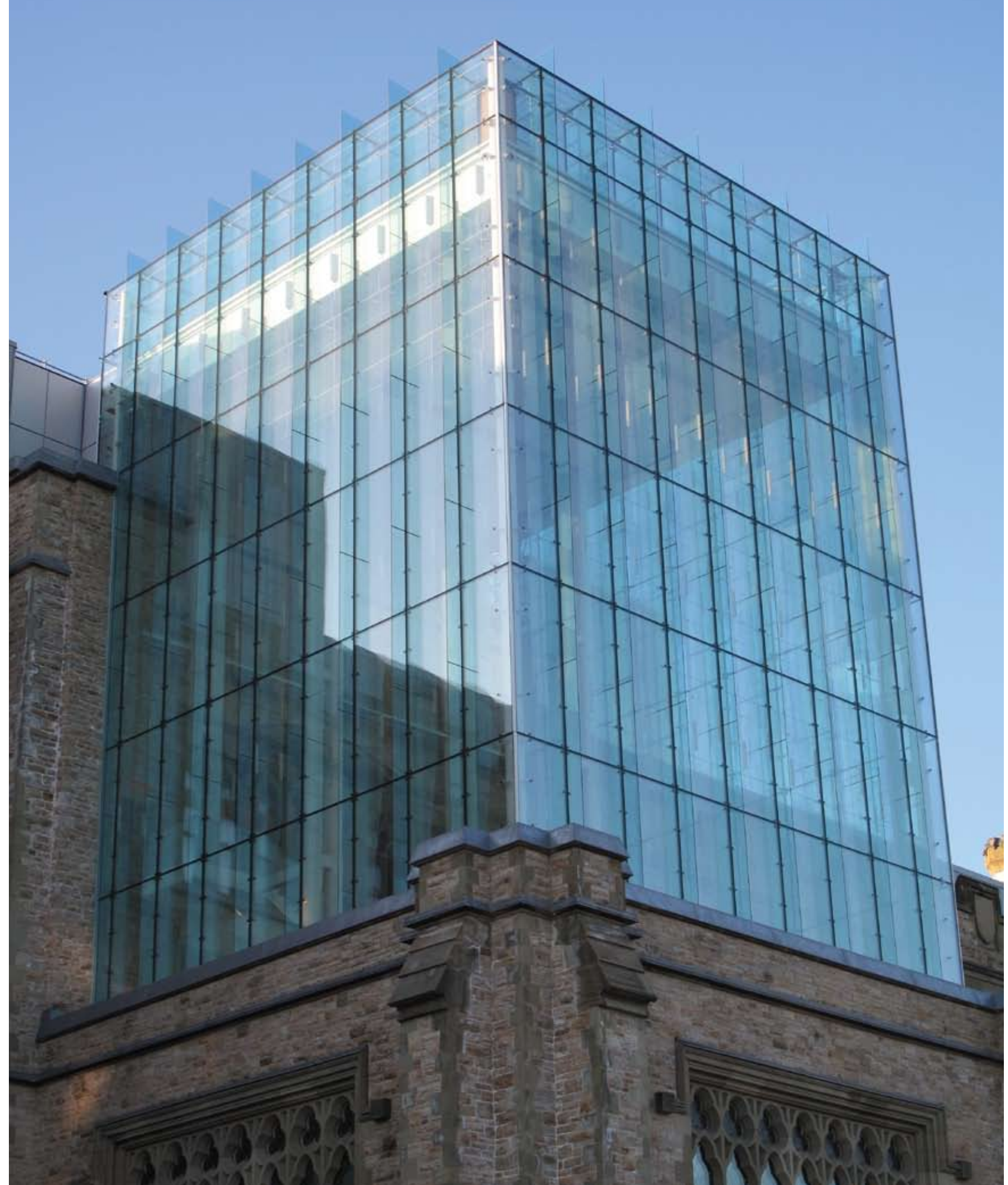



DUAL SKIN CLIMATE WALL

PROJECT
New York Presbyterian
Hospital

LOCATION
New York, NY

ARCHITECT
Pei Cobb Freed
& Partners

NEW YORK PRESBYTERIAN HOSPITAL

The dual skin “climate wall” was designed to allow significant quantities of natural daylight into the space and to act as a natural insulator.

The outer wall of laminated glass is mounted to a series of stainless steel tension rods by countersunk Planar fittings and cast stainless steel “spiders”. The inner wall of insulated laminated glass is separated by a 3’ gap that acts as a thermal barrier and allows for the deployment of computer controlled shading devices as well as cleaning. In the winter the facade acts as a large thermal blanket for the space, reducing heating costs.



Interior view of atrium wall supported by a series of horizontal steel and cable trusses to take both wind and dead load

BOTH WALLS OF GLASS ARE MADE FROM PILKINGTON OPTIWHITE™ LOW IRON GLASS. THE OUTER WALL UTILIZES A SENTRYGLAS INTERLAYER FOR BOTH STRUCTURAL INTEGRITY AS WELL AS TRANSPARENCY.

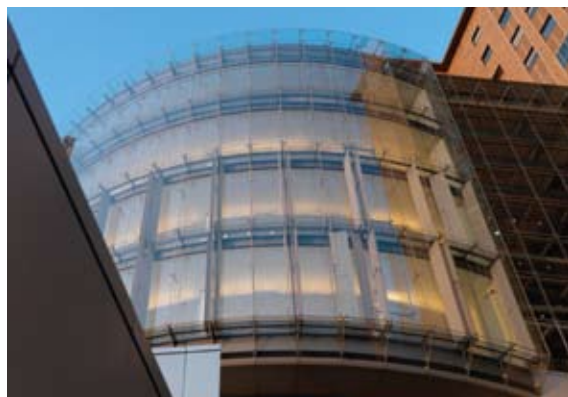

The exterior and interior facades are separated by a 3’ gap that accommodates both shading devices as well as stainless steel tension trusses for structural support

**UNIVERSITY OF SOUTHERN CALIFORNIA
STEM CELL RESEARCH BUILDING**

THE EXTERIOR PLANAR FACADE IS A CABLE WALL SPANNING APPROXIMATELY 63' MADE UP OF PILKINGTON OPTIWHITE™, LOW IRON, LAMINATED GLASS MOUNTED TO STAINLESS STEEL CABLES BY PLANAR 905 TYPE STAINLESS STEEL MACHINED FITTINGS. THE FITTINGS ARE CLAMPED ONTO THE CABLE WITH SPECIALLY MADE RODS AND BOLTS.

The interior facade is a conventional window wall spanning floor to ceiling with insulated Low-E glass with a 50% acid etch frit pattern.

The cavity of 3' between facades is filled with walkways for access to the exterior facade and for maintenance. This space creates a thermal barrier to better insulate the interior of the building.



DUAL SKIN CLIMATE WALL

PROJECT
University of Southern
California Stem Cell
Research Building

LOCATION
Los Angeles, CA

ARCHITECT
ZGF Los Angeles

THIS DUAL SKIN CABLE WALL, ON THE WEST COAST, ACTS AS BOTH AN ACOUSTICAL AND THERMAL BARRIER FOR THIS NEW RESEARCH BUILDING.

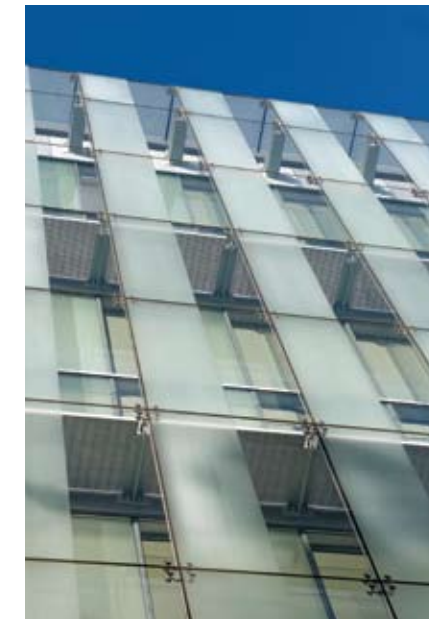

The exterior facade is supported by a series of pre-tensioned stainless steel cables that span top to bottom and are laterally braced at each floor. The glass panels are mounted to the cables by 905 countersunk Planar fittings.

JUILLIARD SCHOOL/ALICE TULLY HALL, NEW YORK, NY

PILKINGTON PLANAR™ STRUCTURAL GLASS WAS USED ON 4 DIFFERENT FACADES AT THE NEWLY RENOVATED AND EXPANDED JUILLIARD SCHOOL OF MUSIC AND ALICE TULLY HALL AT LINCOLN CENTER ON BROADWAY & 65TH STREET.

The focal point of the project is the single span cable wall that faces Broadway and serves as the main entry into the complex. A series of stainless steel cables up to 1.25" diameter span heights of 45' and are tensioned up to 60kips each. 3/4" Pilkington Planar™ clear laminated glass mounted to the cables by use of both Planar Integral fittings and stainless steel patches serves as the skin to this facade.

Other Planar facades utilize bolted, insulated laminated glass for insulation, security and acoustical control and are supported by laminated glass fins.

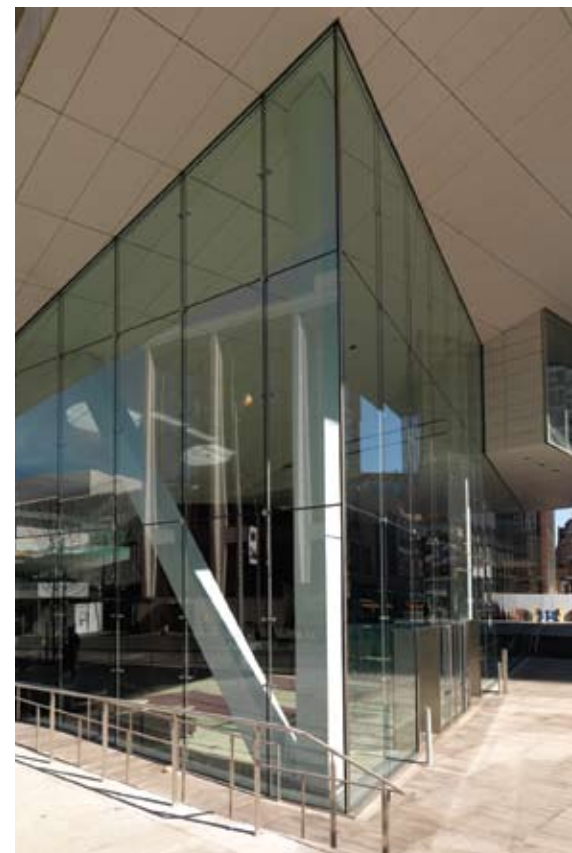

Stainless steel fittings in both countersunk and patch plate forms were used to mount the laminated glass to the stainless steel cables. The larger patch fittings were used at the four way intersections and the small Planar integral fittings were used at the intermediate locations to reduce deflection.



BANK OF AMERICA TOWER, NEW YORK, NY

**NEAR THE HEART OF TIMES SQUARE, ON 42ND STREET,
ACROSS FROM BRYANT PARK IS A LIGHTWEIGHT CABLE WALL
ALLOWING FOR PANORAMIC VIEWS OF THE BUSTLING CITY.**

The architect utilized the Pilkington Planar™ Net system for this lobby enclosure because of its light weight appearance underneath a massive 50 story skyscraper. The entry lobby spans 37' and utilizes a single span ¾" stainless steel cable, pre-stressed to 30 kips, to hold up low iron SentryGlas laminated panels mounted by 905 type countersunk Planar fittings. The contrast between the massive vertical columns and the light weight stainless steel cables allows the facade to disappear.

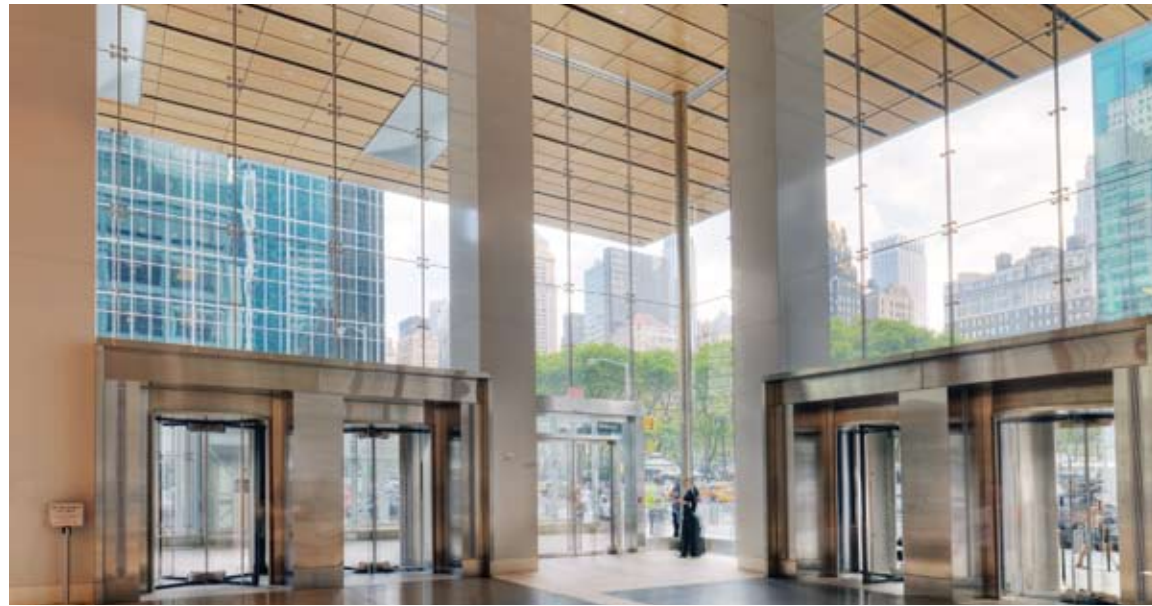

At the north elevation of the tower is the Stephen Sondheim Theatre whose facade was maintained during construction. Immediately adjacent on both sides are two 30'x70' Planar Net walls which helped unite the classic brick facade and the all glass tower.

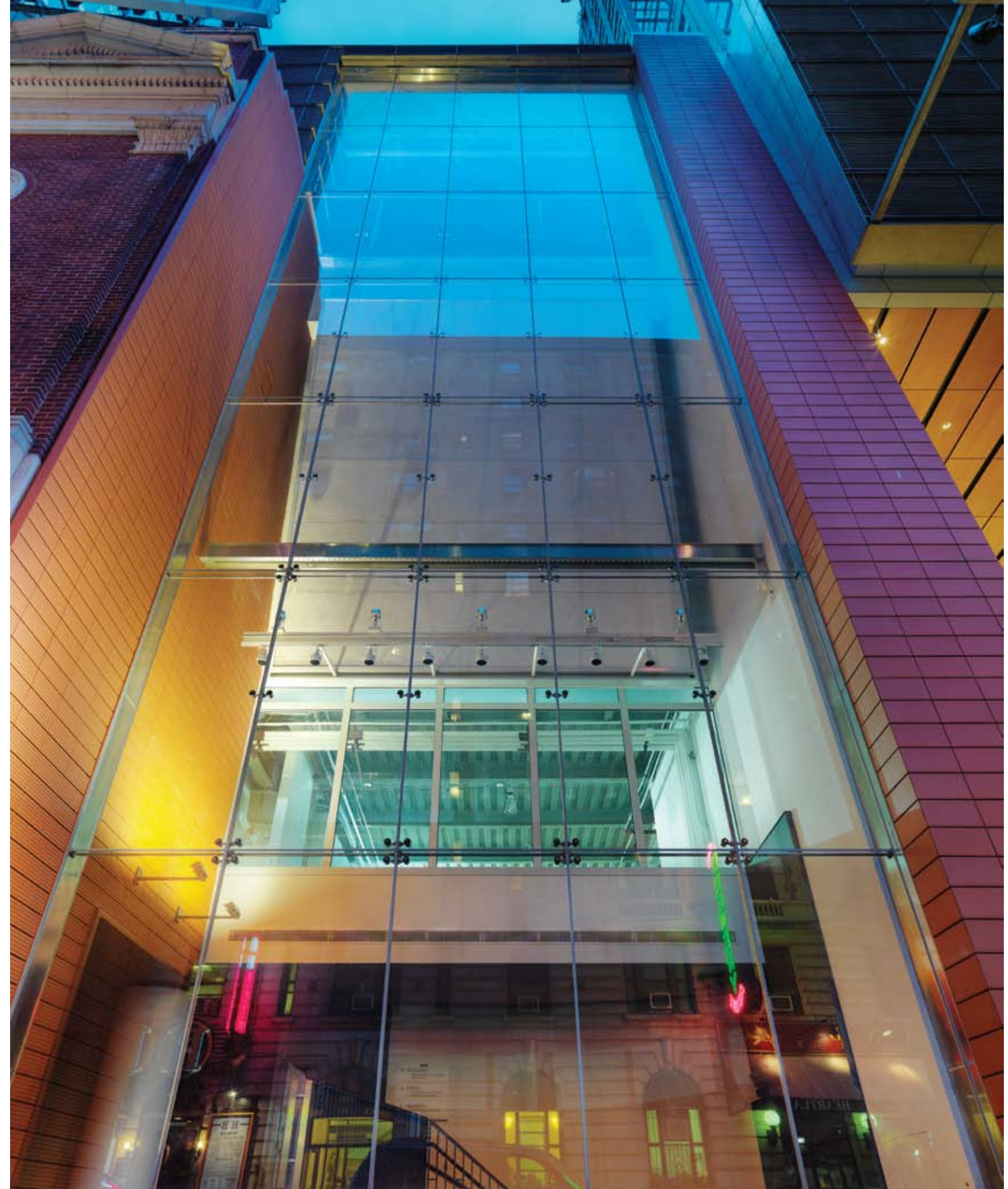

PROJECT
Bank of America Tower

LOCATION
New York, NY

ARCHITECT
Cook+Fox Architects



PROJECT
Indianapolis Motor
Speedway

LOCATION
Indianapolis, IN

ARCHITECT
Browning Day Mullins
Dierdorf Architects



PROJECT
One Post Office Square

LOCATION
Boston, MA

ARCHITECT
CBT Architects



Yankee Stadium, Bronx, NY Populous f/k/a HOK Sport
Off in the distance is the "Batter's Eye" which is a grey
tinted Pilkington Planar™ integral laminated glass
facade that conceals a sports bar in center field.

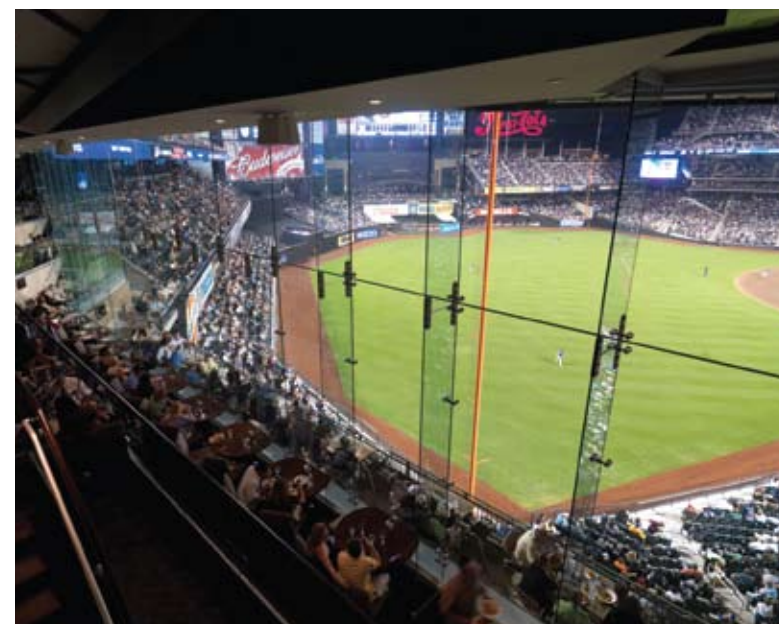

Citifield (NY Mets Stadium), Flushing, NY Populous f/k/a HOK Sport
Vertical glass fins support laminated glass mounted by 905 Planar
fittings to create this large viewing window from the right field
dining club.



ONE POST OFFICE SQUARE

AFTER A CHANGE IN OWNERSHIP OF THIS HIGH-RISE
BUILDING, A NEW LOBBY WAS CREATED OUT OF LOW
IRON OPTIWHITE™ GLASS.

The new facade is supported by 19mm low iron Optiwhite™
glass fins and utilizes a "fly-by" at the head and jambs to
create the illusion of a floating facade. Custom laminated
glass transfer beams were introduced to help create an
all glass entry portal to encase both the revolving and
balanced doors.



PROJECT
AMC Theatre

LOCATION
Los Angeles, CA

ARCHITECT
STK Architects



PROJECT
Columbia Center

LOCATION
Washington, DC

ARCHITECT
Hickok Cole Architects

AMC THEATRE

W&W WORKED WITH WESTFIELD, THE MALL'S OWNER, AND THE ARCHITECT TO CREATE THE ULTIMATE TRANSPARENT GLASS WALL FOR THIS MOVIE THEATER ADDITION IN CENTURY CITY.

Panels are made from 12mm Pilkington low iron Optiwhite™ glass and span 45' and lean out at a 10 degree angle. The facade is held up by 3/4" low iron Optiwhite™ glass fins and 905 type stainless steel Planar fittings. Laminated glass canopies supported by laminated glass fins were introduced over each entry portal. These canopies are particularly invisible and also utilize low iron Optiwhite™ glass.

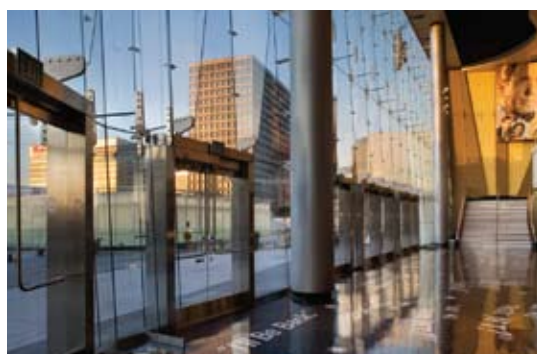

THE LOW IRON ALL GLASS JEWEL BOX THAT FORMS THE CORNER OF THIS OFFICE BUILDING IS THE FOCAL POINT OF THIS PROJECT.



COLUMBIA CENTER

OPTIWHITE™ LOW IRON GLASS WAS UTILIZED FOR THE VERTICAL GLASS FINNS, THE HORIZONTAL GLASS BEAMS SUPPORTING THE CANOPY, THE RETURN LIGHTS ON THE ROOF AND THE ENTIRE FACADE.

Stainless steel countersunk Planar fittings join the panels together and allow for a structureless glass corner that help make the illusion of a floating cube.



PROJECT
Novartis

LOCATION
East Hanover, NJ

ARCHITECT
Gensler

NOVARTIS

PILKINGTON PLANAR™ INSULATED GLASS ON THE VERTICAL WALL AND INSULATED LAMINATED GLASS ON THE SKYLIGHT.

The glazing system is made up of a series of horizontal steel plate beams and vertical stainless steel tension rods. Glass is mounted to the rods and/or plate beams with stainless steel countersunk Planar fittings. The glass panels are made up of low iron Pilkington Optiwhite™ glass with a high performance Low-E coating for energy efficiency.



Horizontal painted steel plate beams resist wind load from the glazing and transfer it to the vertical steel jambs.



PROJECT
601 Lexington Avenue
(Citicorp Tower)

LOCATION
New York, NY

ARCHITECT
KlingStubbins

601 LEXINGTON AVENUE

BOSTON PROPERTIES, THE OWNER OF THE CITICORP TOWER WAS LOOKING TO CREATE A NEW, CLEAN AND ELEGANT ENTRY AT THE REAR OF THE TOWER ON LEXINGTON AVENUE.

A simple design of painted steel plate beams (1.5" thick) were used to support an exterior wall of Pilkington Optiwhite™, low iron, laminated glazing spanning over 35' and returning to form a small skylight at the roof. Glass panels were mounted with stainless steel countersunk Planar fittings.

This was a design assist project with W&W, Kling Stubbins architects and Thornton Tomasetti engineers. The result is a true jewel box entry into this iconic NY skyscraper.



Side mounted spider stainless steel castings and Planar 902 countersunk fittings attach the laminated glass to the vertical plate beams.



PROJECT
Brooklyn Museum of Art

LOCATION
Brooklyn, NY

ARCHITECT
Polshek Partnership

BROOKLYN MUSEUM OF ART

THE 15,000 SQ. FT. SHINGLED GLASS PAVILION CREATES A NEW ENTRANCE AREA TO THE 107 YEAR OLD MUSEUM.

The glazing system is made up of a series of laminated glass panels with a ceramic frit silk screen pattern for solar control. It is supported by a combination of painted steel plates and stainless steel truss assemblies. Pilkington Optiwhite™ low iron glass and custom stainless steel castings make up the vertical enclosure around the glass roof. W&W was responsible for the entire enclosure including engineering, glass and steel, fabrication and erection.

This project truly represents a coming of age for classic architecture combined with state of the art glazing technology!



Custom designed painted steel beams and stainless steel castings created the support for this stepping glass roof.

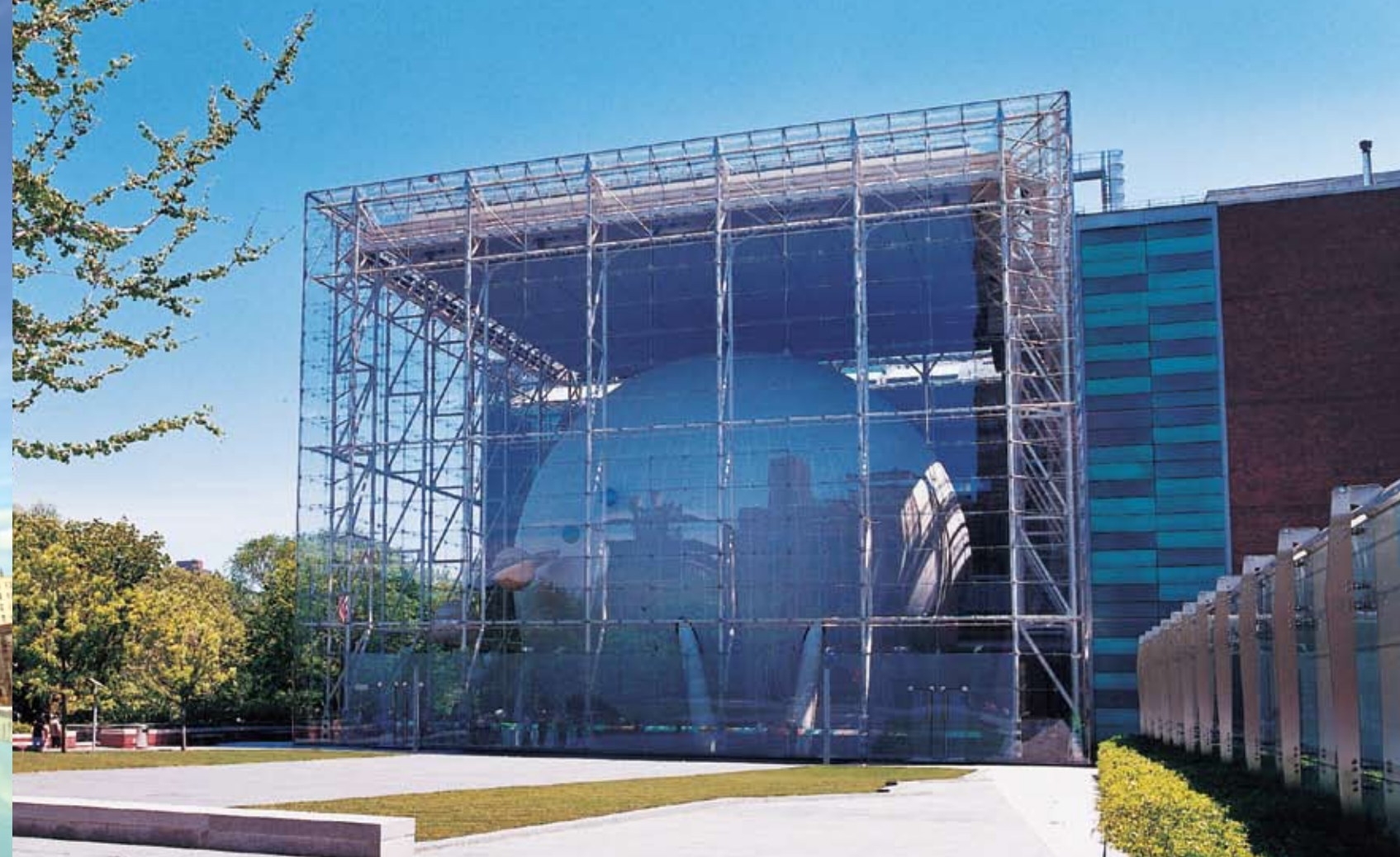

PROJECT
The Rose Center for Earth and Space

LOCATION
New York, NY

ARCHITECT
Polshek Partnership

THE ROSE CENTER FOR EARTH AND SPACE REPRESENTS THE PINNACLE OF CABLE STAYED STRUCTURAL GLAZING IN THE UNITED STATES TODAY.

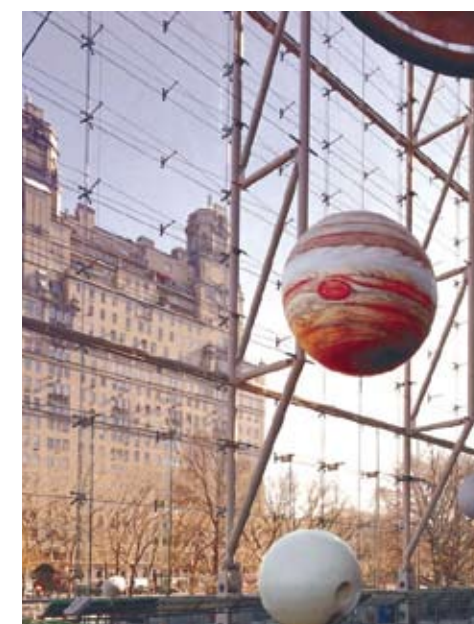

Vertical pipe trusses and horizontal cable trusses create this most transparent facade.

THE ROSE CENTER FOR EARTH AND SPACE

PUSHING THE LIMITS OF STRUCTURAL GLASS TECHNOLOGY AND TRANSPARENCY TO THEIR FULLEST POTENTIAL, THE TWO MAIN PILKINGTON PLANAR™ FACADES REACH 95 FEET ABOVE THE TERRACE LEVEL.

These two facades soar to a continuous glass skylight that runs around the full 490 ft. perimeter of the building. Each facade is glazed in Pilkington Optiwhite™ low iron glass, over 34,000 sq. ft. in all. Each glass panel is held in place by custom designed and manufactured stainless steel castings with a custom glass bead blast finish.

W&W had overall contract responsibility for the entire enclosure including not only the Pilkington Planar™ system, but also the complex tubular steel trusses and the stainless steel rigging/tension structure.

W&W GLASS, LLC

302 Airport Executive Park · Nanuet, New York · 10954-5285
800.452.7925 · 845.425.4000 · Fax 845.578.1596 · wwglass.com

All glazing components in this brochure have been supplied by Pilkington. Certain backup structural elements displayed in photographs within this brochure have been supplied by others. This publication gives a general description of the product. It is the responsibility of the user to ensure that any use of the system fully complies with all relevant building codes, industry standards and other requirements. Pilkington and W&W hereby disclaim all liability arising from any error in or omission from this publication. Pilkington Planar™, Pilkington Optifloat™, Pilkington K Glass™, Pilkington Activ™ Pilkington Optiwhite™, Pilkington Insulight™ are all trademarks of Pilkington United Kingdom Limited. DuPont™, the DuPont Oval and SentryGlas® are registered trademarks or trademarks of E.I. DuPont De Nemours & Co. or its affiliates and are used under license from the trademark owner. SPECIFICATIONS SUBJECT TO CHANGE. 2011 © COPYRIGHT, W&W GLASS, LLC. PRINTED IN USA.